

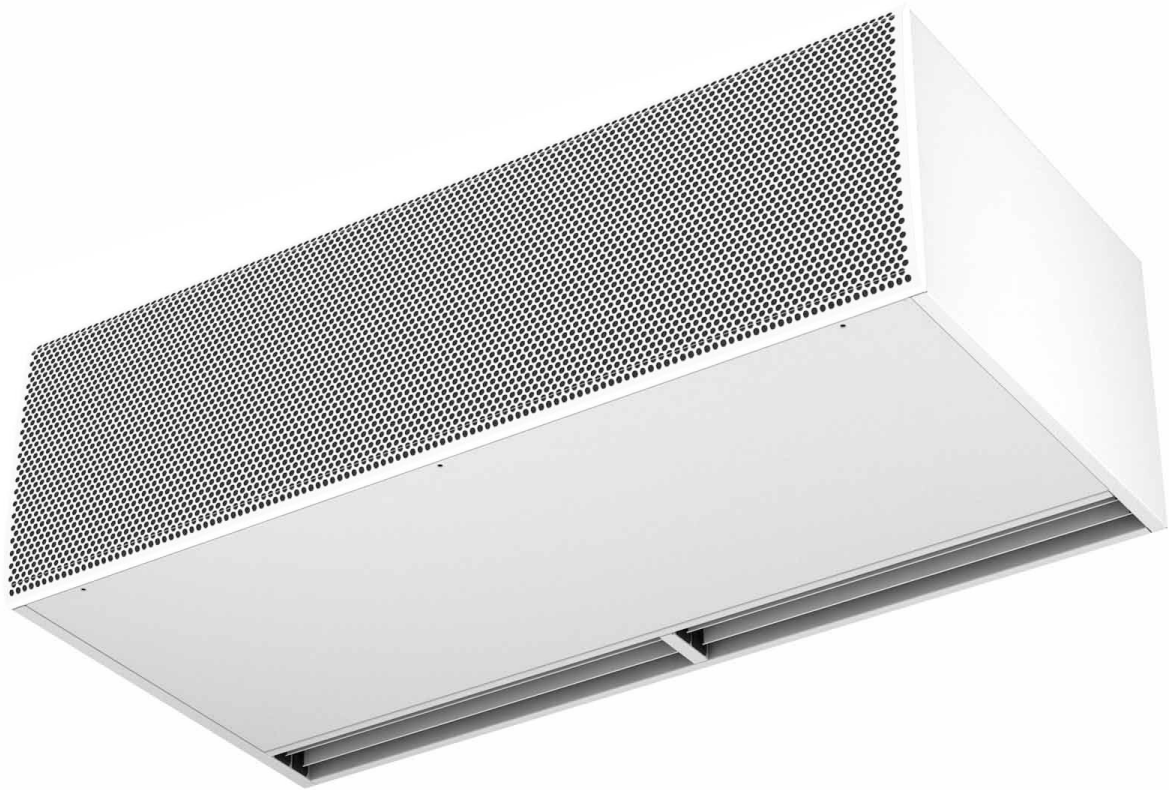

INSTALLATION, OPERATION AND MAINTENANCE MANUAL



Air Curtains WINDBOX L, XL

Please, read these instructions carefully before attempting installation

SECURITY ADVISE SYMBOLS



Attention, Danger, Safety Advice!



Danger from electric current or high voltage!



Injuries risk!



Danger! Do not stay underneath: Heavy load.



Important information.

AIRDOM05012-R13(29/05/2020)

INDEX

CONNECTION DIAGRAM (WITHOUT HEATING OR WITH WATER ELEMENT)	3
CONNECTION DIAGRAM (ELECTRICAL HEATING)	4
INSTALLATION	5
Power Supply	5
PCBoard and Control	5
Fixing.....	6
Water coils	6
Electrical elements	6
STORAGE AND TRANSPORT	6
WORKING INSTRUCTIONS	7
Control PCBoard characteristics	7
Controller's common characteristics	7
Common characteristics to all controllers for water heated air curtains	7
Common characteristics to all controllers for electrical heated air curtains	8
Special controllers	8
Remote control characteristics	9
WIRING DIAGRAMS	9
DATASHEET	24
MAINTENANCE INSTRUCTIONS	26
External cleaning.....	26
Internal cleaning.....	26
REPAIRS AND REPLACEMENTS	27
Fan replacement	27
Fuse and PCB replacement	28
Heater replacement.....	28
FAILURES AND SOLUTIONS.....	29
ACCESSORIES	30
DECLARATION OF CONFORMITY	31
Air curtain identification	32
GUARANTEE	32

CONNECTION DIAGRAM (WITHOUT HEATING OR WITH WATER ELEMENT)

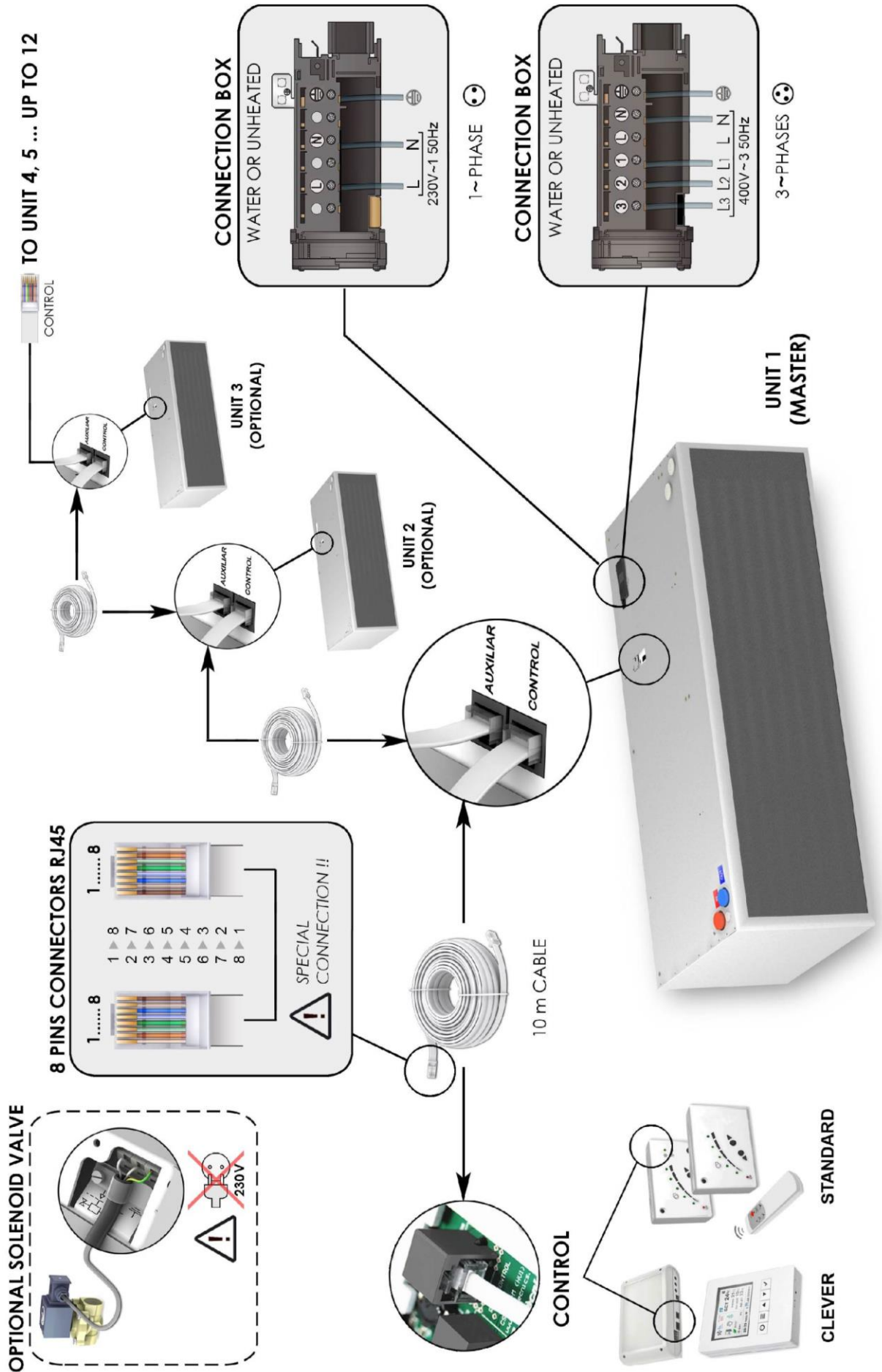

CONNECTION DIAGRAM (ELECTRICAL HEATING)

TO UNIT 4, 5 ... UP TO 12

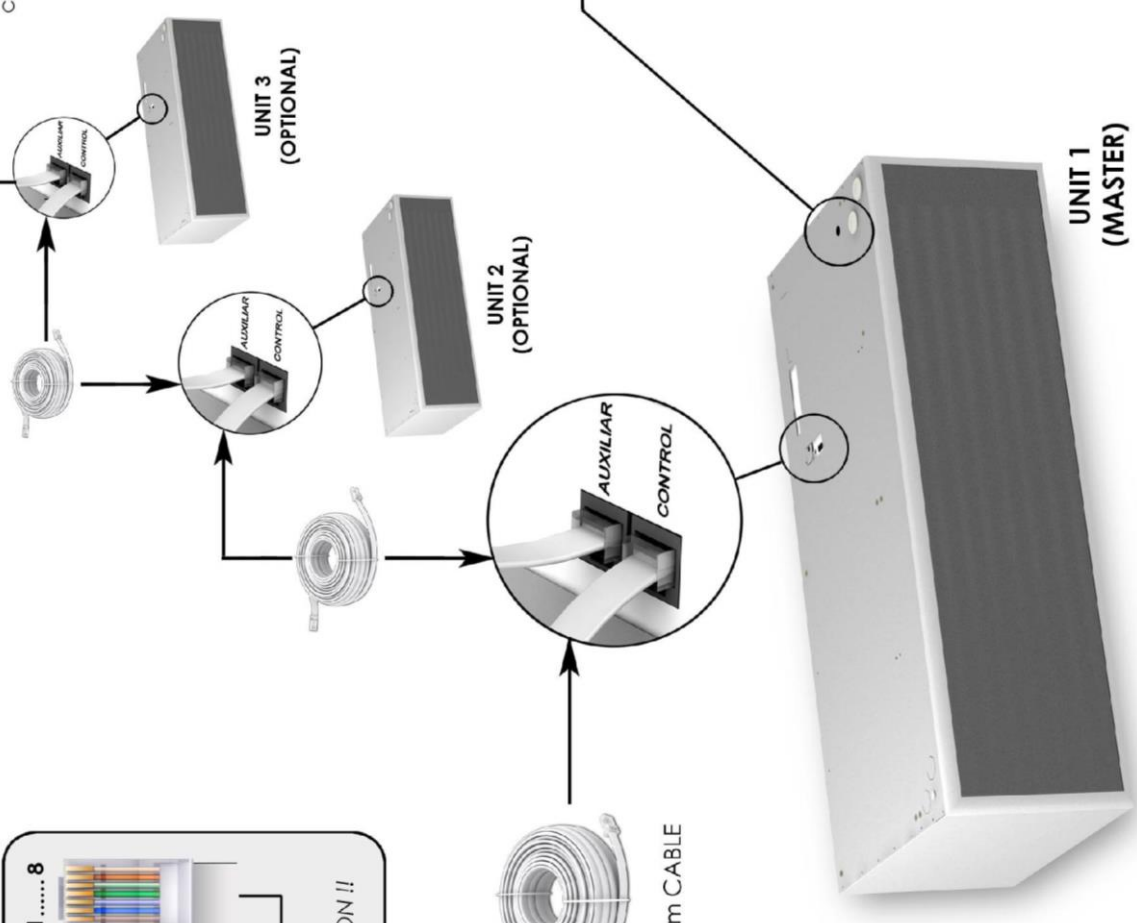
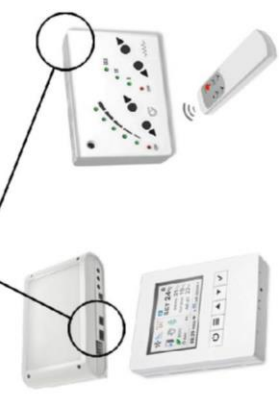
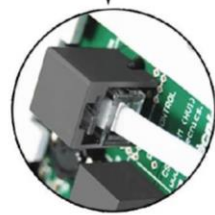
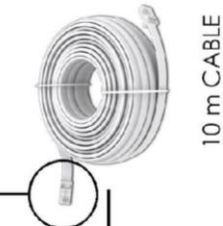
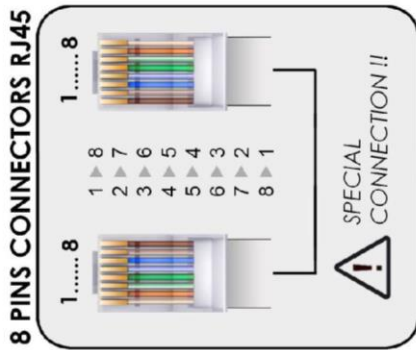

ELECTRICAL HEATING

1. Open the service door.



2. Pass the cable through the hole down to the power terminal.



3. Connect the cables at the electrical element as the picture shows:

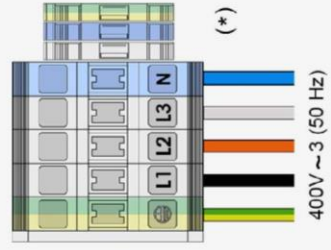

(*) Depending on the power of electrical heating, you may need two separated power supply lines

INSTALLATION

Valid for models: **Windbox L, XL**

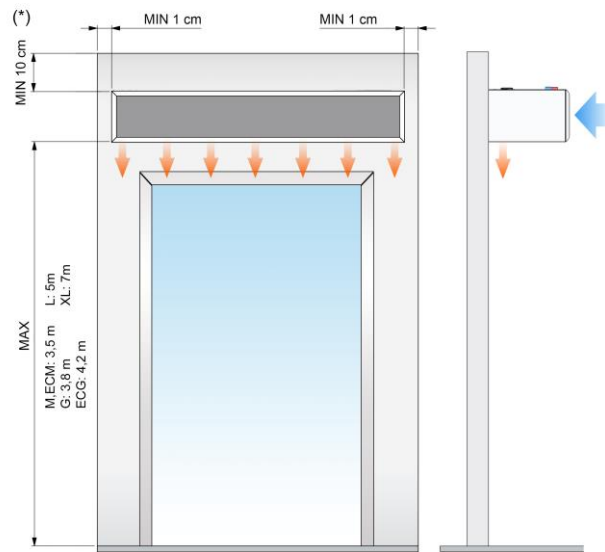

MAX. Maximum recommended height, MIN. Minimum recommended distance

(*) Standard units. Under request this distance can be reduced up to 1cm when connections are placed inside and when lateral water pipes

Minimum recommended distance between the inlet grille and any obstacle is of 400mm.

	<i>Installation work, connection, disconnection, electrical wiring, mechanical maintenance and service must be done by qualified people observing these instructions and in accordance with all applicable norms and standards. If the unit is operated with additional controller, please consider its specific instructions.</i>
	<i>There is no need to open the service door to connect the air curtain. All connections (power supply, control, water pipes when existing) and fixations are external. They are placed on top or lateral of the units. See how to open service door at repairs section.</i>
	<i>For safety, the air curtains never have to be stopped by disconnecting them from the main supply, always through the controller and waiting 10 minutes at least to disconnect the main supply. In case of not follow these instructions, the internal parts of the air curtain can be damaged.</i>

Power Supply

To connect the power supply there is a black connection box outside the air curtain (located on top).

For an ambient air or water heated air curtain, just connect the single phase 230Vx1.

In case of an air curtain with electrical heating we will also connect the three phase 400Vx3 of the electrical element. Optionally under request the power supply of the water coil or electrical element can be three phase 230Vx3 or single phase 230Vx1 depending on each model (special wiring diagram will be enclosed).

PCBoard and Control

To connect the controller there is a PC Board (printed circuit) located outside the air curtain (located on top). There is no need to open the unit to connect it.

Use the 10 meters RJ45 cable supplied with the equipment. The communication between the controller and the PCB is digital and low-voltage.

Optionally, there are different accessories and controllers available, to meet every customer needs (Clever Control, thermostats, hand-auto, door contacts, anti-freezing sensor, supports, valves, etc.).

The new total control for ventilation technology is advanced *Clever* regulation. Leading the new generation of air curtains management with maximum control providing maximum energy saving. *Clever* automatically adapts the functioning of the air curtain to the entrance climatic conditions in order to keep the comfort and energy saving.

For more information ask for *Clever Control* manual.

Fixing

Units are provided of several external suspension points, depending on the weight and length of each model (see exact situation of the points at the air curtains characteristics page).

Generally air curtains work horizontally but also can be installed vertically using feet supports (*Accessories* section).

The fixing of the air curtain should be managed according to the weights of each unit shown on the technical data page. The installation can be made through threaded rods, cable tensors or other supports. See available supports in the accessories section.

Water coils

Water heated air curtains have a PCBoard with an output of 230Vx1 to install an electro valve (open/close water entrance) or any other device.

It is recommended:

- Close the hot water circulation (by turning the electrovalve OFF) to avoid fan overheating while the unit is OFF. Electrovalve is optional.
- Install 2 cutoff water valves (supply and return) in order to disassemble the equipment easily.
- Install a bleeding valve at the highest part of the water heating circuit.

The ambient temperature should be always over +4°C, otherwise it will be necessary to provide an anti-frost protection device.

Water coils have a drainage point placed at the end part of the intake manifolds area.

Some special units are provided with condensation tray prepared to work with cold water. In this case, these units can't work at high ventilation speed (depending on model, length and power it will be a speed limitation). Intake air speed should not be higher than 3m/s because water drops can appear on the outlet.

Electrical elements

The heater element has from 15 to 24 resistances bars (depending on the model) that combined give 3 stages of heating. The control is made through contactors.

All electrical elements are protected electrically and electronically against overheating (see "*Operating instructions*" section).

The electrical controllers have the option to install an external thermostat that turns on/off the heating in order to control the temperature.

During the first uses scent can be emitted but it disappears in a few days.

STORAGE AND TRANSPORT



**Attention! Heavy load.
Do not step underneath hanging load during the transport or assembly.**

Store in a dry place and weather protected in its original packaging. In case the packing is opened, cover the air curtain to protect it from dust. Do not step or put heavy load over the package to avoid damages to the material. Store temperatures are between -20°C and +40°C.

When carrying material, make sure it is not damaged by the forklift (fork penetration in the packaging). Please see the *Packaging* indications.

WORKING INSTRUCTIONS



For safety, the air curtains never have to be stopped by disconnecting them from the main supply, always through the controller and wait for 10 minutes at least to disconnect the main supply. In case to not follow these instructions, the internal parts of the air curtain can be damaged.

Control PCBoard characteristics

Fan speed is regulated through the input voltage variation of the fans set. The transformer has 5 output voltages: 120, 140, 170, 200 and 230 Volts.

Controller's common characteristics

- **Controllers:** There are several models depending on the customer's needs (timers, anti-freezing detectors, thermostats, etc.).
- **5 ventilation speed.**
- **Memory:** When a power shortage happens, it guarantees that the selected speed will be maintained when the service is re-established. This function can be connected or disconnected through the switch ON/OFF placed inside the controller.
- **RJ45 cable and digital communication:** "Plug and Play" easy and fast connection through RJ45 cable and digital communication between the controller and the air curtain. This kind of communication is more reliable even at long distances.
- **External ON/OFF:** Inside the controller we can connect a normally open contact (1, 2) that controls the ON/OFF of the equipment through any external device, the contact is potential-free. When the contact is Open, the air curtain is ON. When the contact is closed the air curtain is OFF. It has a 30 seconds delay. It can be used with programmable timer, temperature sensors, fire alarms, PLC, etc.
- **Remote control:** All the standard controllers have an IR receiver that works by infrared.



Common characteristics to all controllers for water heated air curtains



Unheated air curtain controller

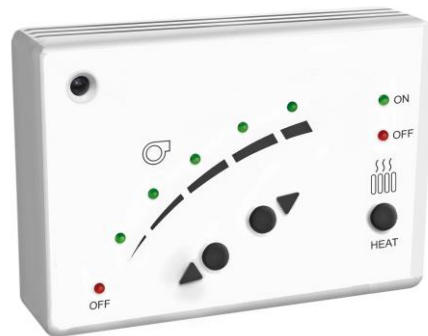

Warm water heated air curtain controller

- **Heating ON/OFF:** It is possible to activate/deactivate the current of 230Vx1 to the electrovalve to open/close the water entrance to the coil. This 230Vx1 output connector is placed on top of the equipment, besides the telephone cable connection of the controller.
- **How to control an electro-valve with an external thermostat:** To control the inlet water to the battery through a thermostat, we must install it in series with the electro-valve. Thus, when it reaches the selected temperature, the electro-valve will close.
- **Safety thermostat:** If the internal temperature increases to 60°C and the first speed being selected, it automatically turns to the second ventilation speed. It will continue to the maximum speed till the internal temperature is lower than 50°C. The emergency operating is indicated by a flashing LED. If the safety activates too often the cause must be determined. The most probable is that we have to increase the cleaning of the inlet grill with more regular recurrence. For example, an obstruction in the inlet grill, the inactive motor or a too high ambient temperature in an installation with no ambient thermostat or a water temperature of the water coil over 80°C would increase automatically the speed fan. It also avoids that the expelled air by the air curtain is over 60°C (too high temperature sensation for people).

Common characteristics to all controllers for electrical heated air curtains

Equipment of five ventilation speed and three different heating powers (C1, C2, C3= [C1 + C2]).



- **3 Heating powers:** C1=1/3 Total, C2=2/3 Total, C3=C1+C2=Total.
- **Limited heating powers:** For safety reasons of the equipment, the heating power is limited by the ventilation speed that we had selected, the following way:

Selected speed	Max. heating power that can be selected
V1	Stage 1 heating.
V2	Stage 2 heating.
V3	Stage 2 heating.
V4	Stage 3 heating (stage 1 + stage 2).
V5	Stage 3 heating (stage 1 + stage 2).
- **Thermostat of delay:** When the equipment is stopped, and the heating has been working, there is an increase in temperature (by inertia) inside the equipment that could damage it. In order to avoid internal damages by overheating, when we stop the curtain and the internal temperature is over 50°C, there is a delay thermostat having the function to turn on again the fans automatically with maximum speed till the temperature goes under 50°C. This safety operating is indicated with a flashing green LED.
- **Safety thermostat:** When the air curtain operates with heating and the internal temperature increases over 60°C, a safety function activates: The air curtain increases one speed every two minutes till it reaches the maximum speed. After, it will start decreasing 1 heating stage till it stops. In case that after 2 minutes the situation persists, the heating will block. To unblock it, we must manually reset by disconnecting from the main supply. If in any moment the temperature decreases (below the set temperature) this process is interrupted and everything goes back to the normal situation.

A delay in the cleaning of the inlet grille or a high ambient temperature could temporarily activate this function.

The air speed and the heating stage are indicated by a continuous lighted LED, while the safety function is indicated by a flashing LED. The blockage of the heating is indicated with the LED OFF of the heating flashing at a higher speed.

Auxiliary functions of the controllers with electrical heating:

- **Ambient thermostat (digital o analogue):** with an ambient thermostat we can turn on and off the heating when reaching a programmed temperature.

Its use is specially recommended in closed areas of little dimensions because otherwise the temperature would increase too much. In case on installing the ambient thermostat, remove the bridge of the controller between terminal 4 and 5.

Special controllers

If there is a will to control more parameters, there are two controllers that allow a lot more possibilities in comparison with the standard control, especially *Clever*. The following controllers have specific user manuals:

- Hand Auto
- Clever Control

Remote control characteristics

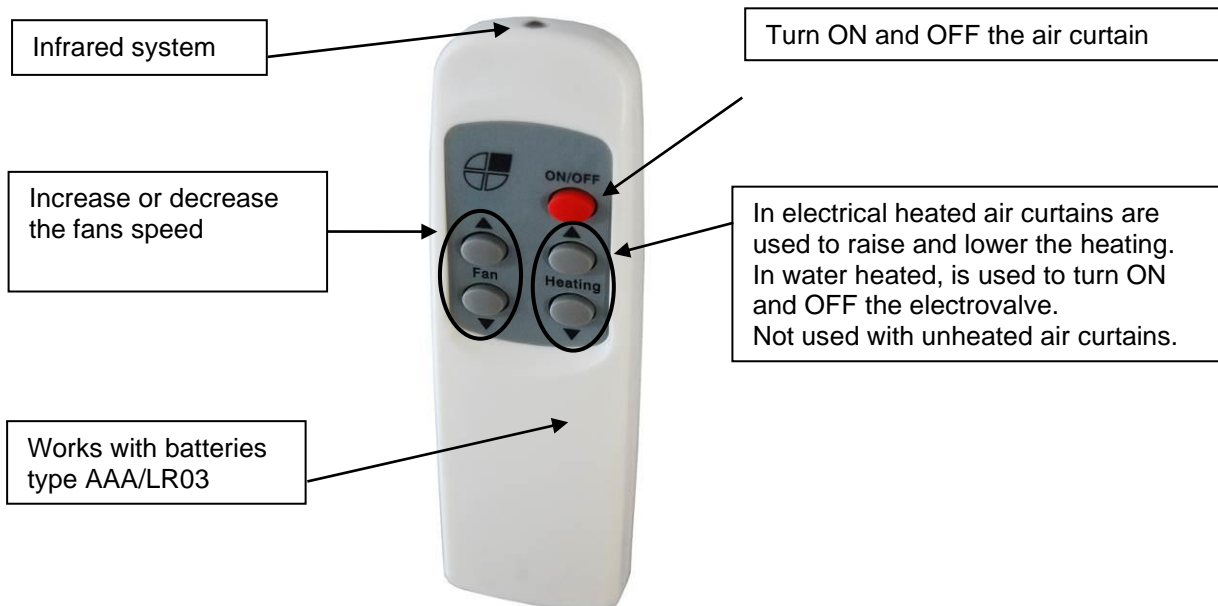

WIRING DIAGRAMS

Following wiring diagrams are enclosed:

- Warm water heated or only air with standard controller L1000-1500 – XL1000. Diagram: AIRDOE09051
- Warm water heated or only air with standard controller L2000-2500-3000 – XL1500-2000. Diagram: AIRDOE09064
- Warm water heated or only air with standard controller XL2500-3000. Diagram: AIRDOE09870
- Warm water heated or only air with Hand Auto controller L1000-1500 – XL1000. Diagram: AIRDOE09251
- Warm water heated or only air with Hand Auto controller L2000-2500-3000 – XL1500-2000. Diagram: AIRDOE09867
- Warm water heated or only air with Hand Auto controller XL2500-3000. Diagram: AIRDOE09880
- Electrical air curtain L 1000, L 1000E25, XL 1000 and L 1500 with standard controller. Diagram: AIRDOE09806
- Electrical air curtain XL 1000 E35 and L 1500 E37,5 with standard controller. Diagram: AIRDOE09821
- Electrical air curtain XL 1500, L 2000, L 2000 E50, XL 2000 and L 2500 with standard controller. Diagram: AIRDOE09850
- Electrical air curtain XL 1500 E52,5 with standard controller. Diagram: AIRDOE09830
- Electrical air curtain L 3000 and XL 2000 E70 with standard controller. Diagram: AIRDOE09858
- Electrical air curtain L 2500 E60, L 3000 and XL 2500 with standard controller. Diagram: AIRDOE09860
- Electrical air curtain XL 2500 E70 and XL 3000 with standard controller. Diagram: AIRDOE09866
- Electrical air curtain XL 3000 E80 with standard controller. Diagram: AIRDOE09876

In case you need to connect the equipment to a PLC, the corresponding wiring diagrams will be supplied.

Reguladores de 5 velocidades
5 Speeds remote Control

Control remoto
Remote control

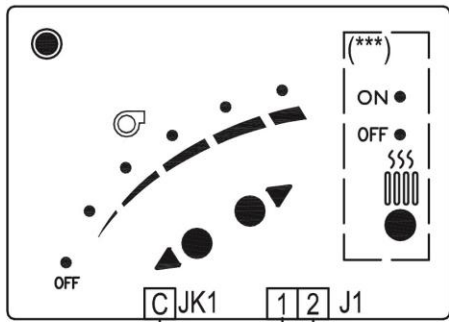

Marcha/Paro externo (opcional) 30 segundos de retardo
ON/OFF Extern (optional) 30 Seconds Delay

Q = Interruptor magnetotérmico
Q = Circuit breaker

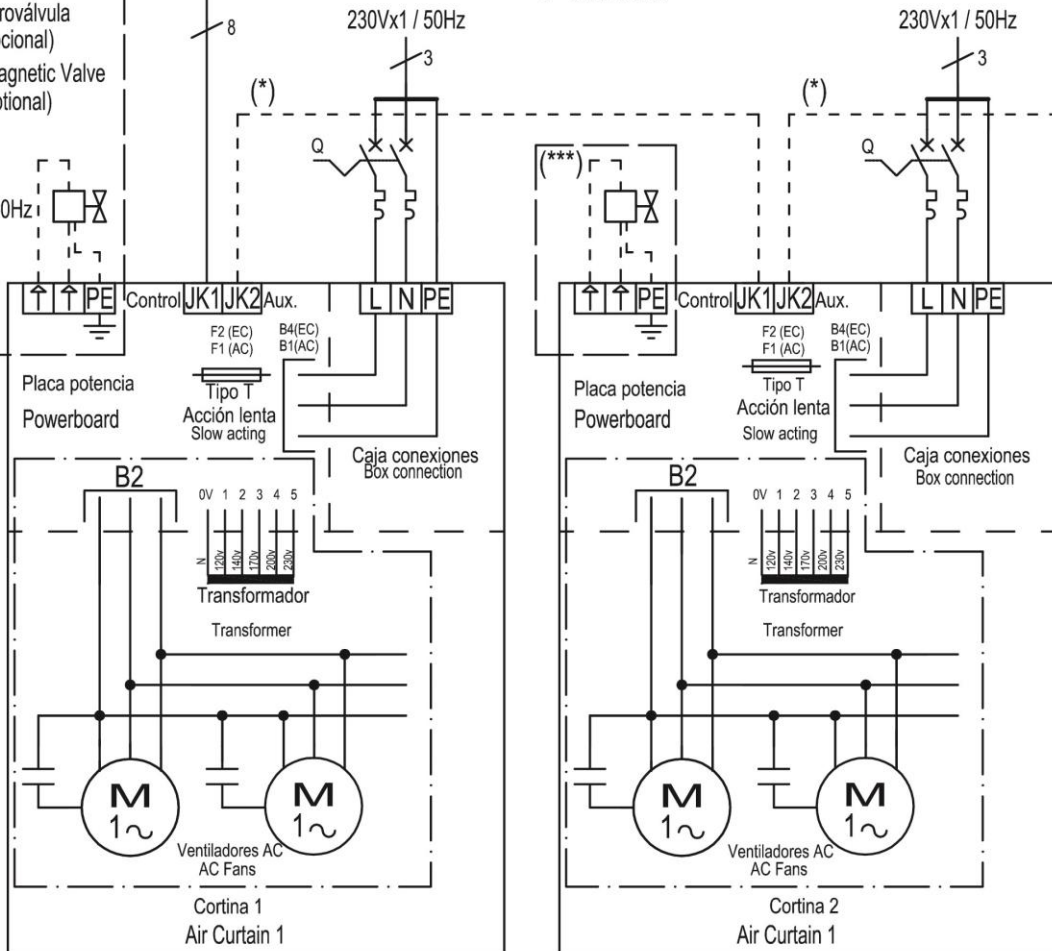
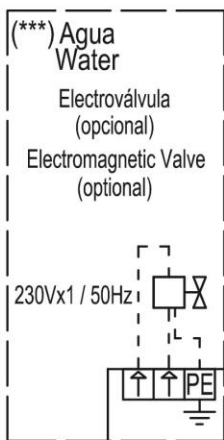

(*) Cortina 2 (opcional, máximo 12)
Air Curtain 2 (optional, Max 12)

ESQUEMAS ELÉCTRICOS CORTINA DE AIRE VENTILADORES AC/EC
WIRING DIAGRAMS OF AIR CURTAIN AC/EC FANS
CONTROLADOR 5 VELOCIDADES AGUA O AIRE L 1000-1500, XL 1000
WATER AND ONLY AIR, CONTROLLER 5 SPEEDS. L 1000-1500, XL 1000

Pág./ Page 1 de/ of 1
Doc. AIRDOE09051
R12 - 17/02/16

Reguladores de 5 velocidades
5 Speeds remote Control

Control remoto
Remote control

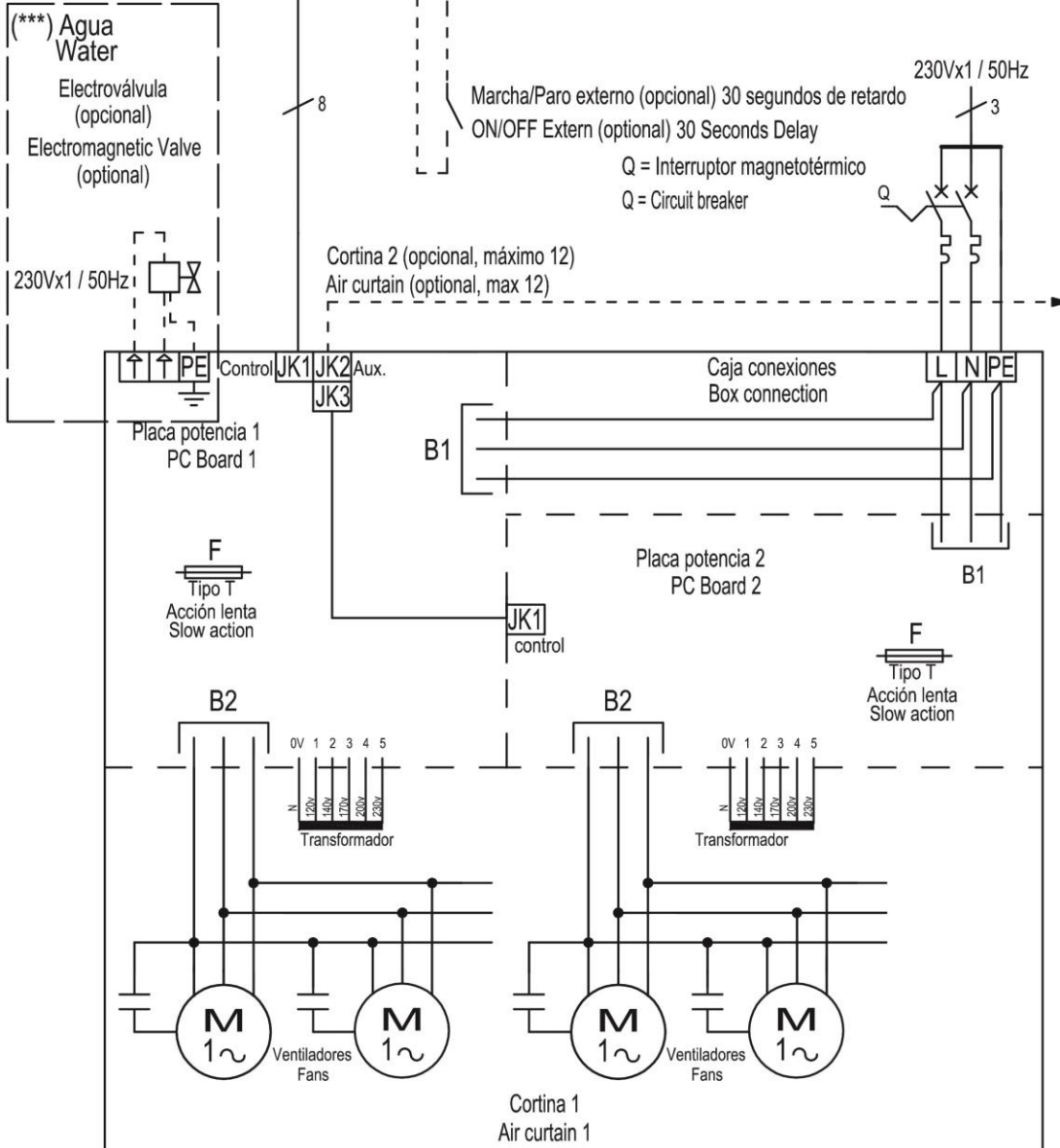
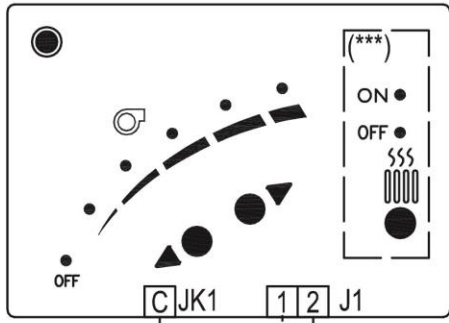

ESQUEMAS ELÉCTRICOS CORTINA DE AIRE
WIRING DIAGRAMS OF AIR CURTAIN

CONTROLADOR 5 VELOCIDADES AGUA O AIRE L 2000-2500-3000, XL 1500-2000
WATER AND ONLY AIR, CONTROLLER 5 SPEEDS. L 2000-2500-3000, XL 1500-2000

Pág./ Page 1 de/ of 1
Doc. AIRDOE09064
R12 - 17/02/16

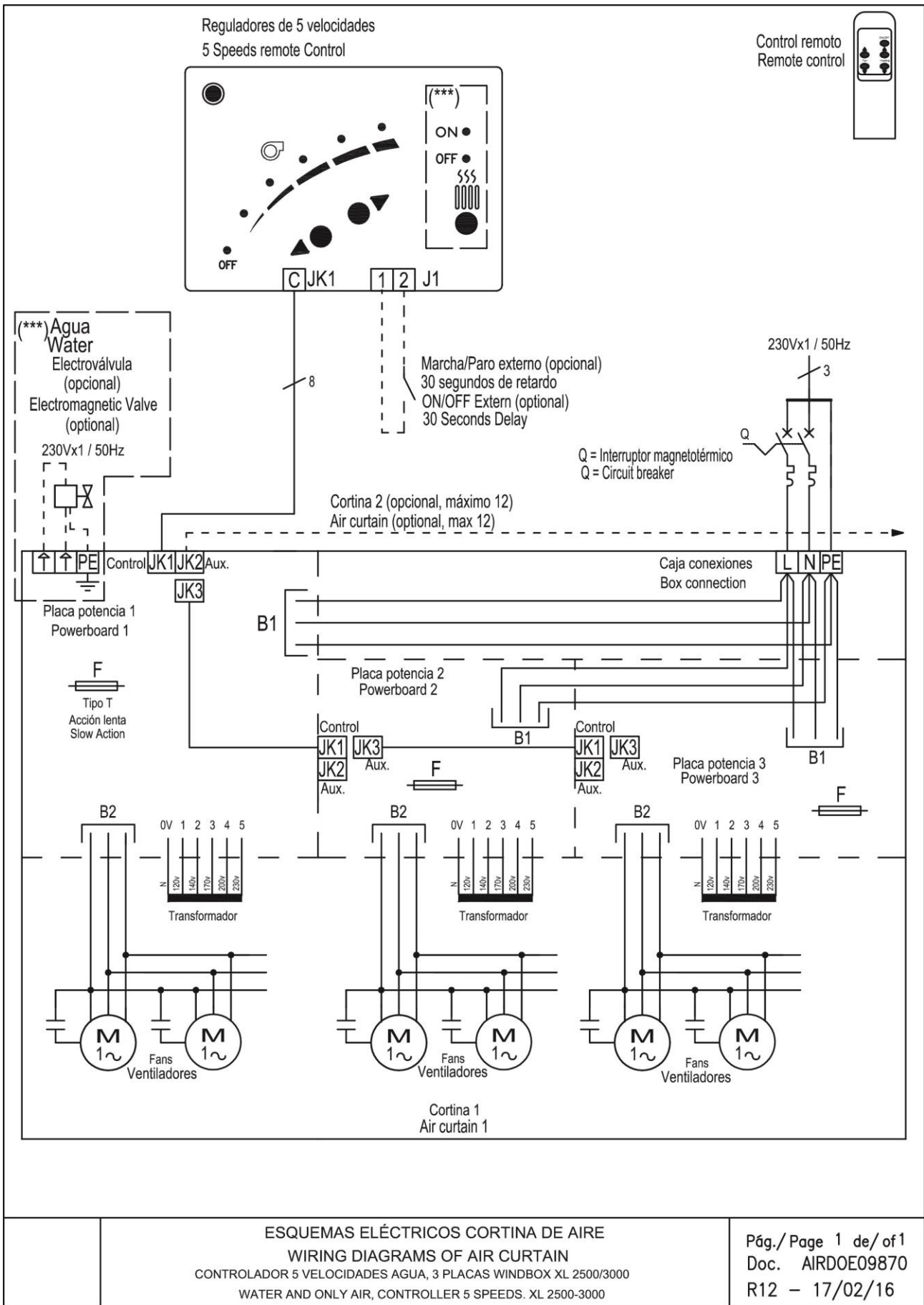

Hand-Auto
Reguladores de 5 velocidades
5 Speeds remote Control

Control remoto
Remote control

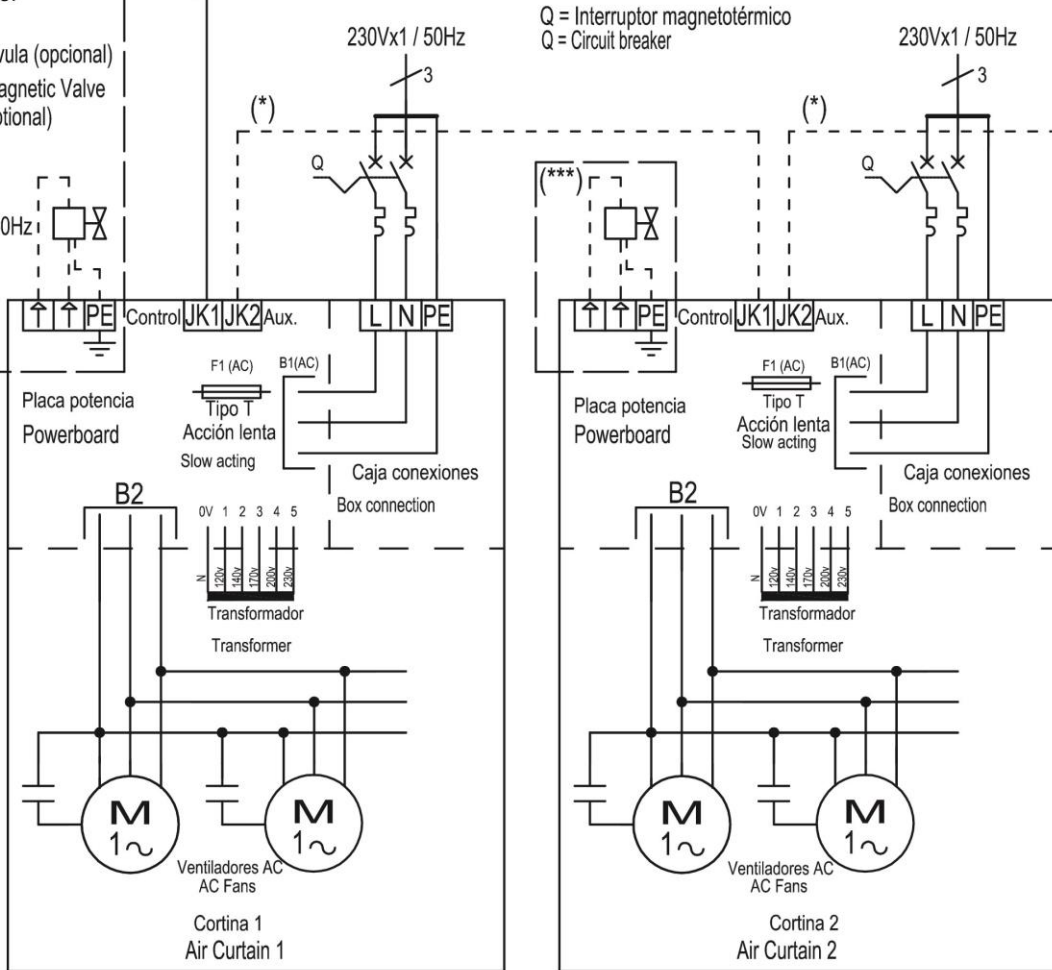
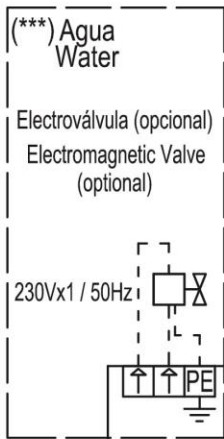
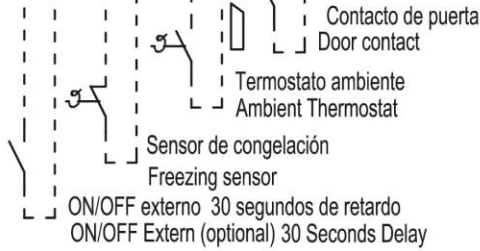
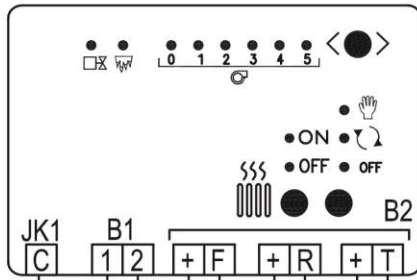

(*) Cortina 2 (opcional, máximo 12)
Air Curtain 2 (optional, Max 12)

ESQUEMAS ELÉCTRICOS CORTINA DE AIRE VENTILADORES AC/EC
WIRING DIAGRAMS OF AIR CURTAIN AC/EC FANS
CONTROLADOR Hand-Auto AGUA O AIRE L 1000-1500, XL 1000
WATER AND ONLY AIR, CONTROLLER 5 SPEEDS. L 1000-1500, XL 1000

Pág./Page 1 de/of 1
Doc. AIRDOE09251
R12 - 17/02/16

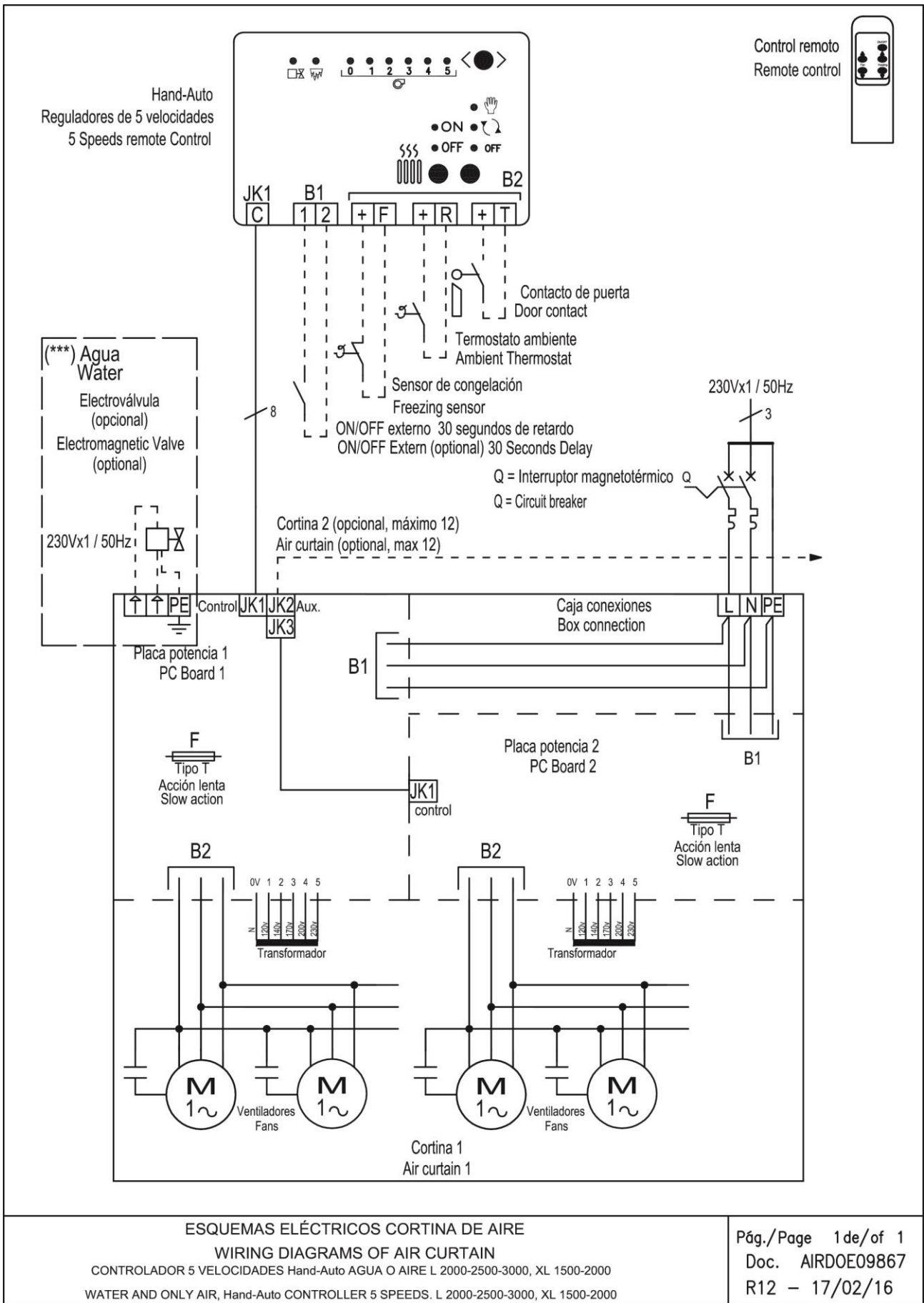

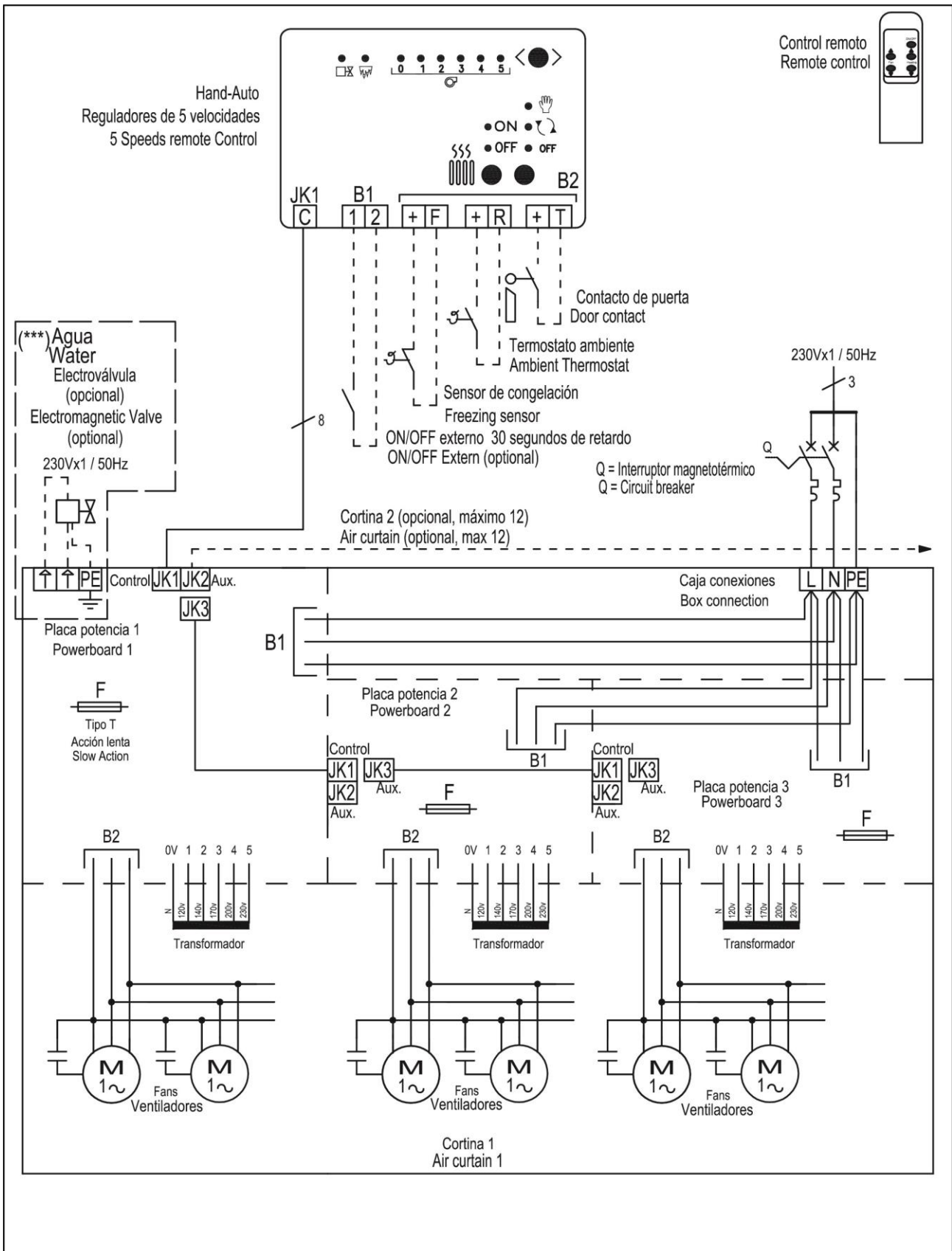

ESQUEMAS ELÉCTRICOS CORTINA DE AIRE
 WIRING DIAGRAMS OF AIR CURTAIN
 CONTROLADOR 5 VELOCIDADES AIRE Y AGUA Hand-Auto, 3 PLACAS WINDBOX XL 2500/3000
 WATER AND ONLY AIR, Hand-Auto CONTROLLER 5 SPEEDS. XL 2500-3000

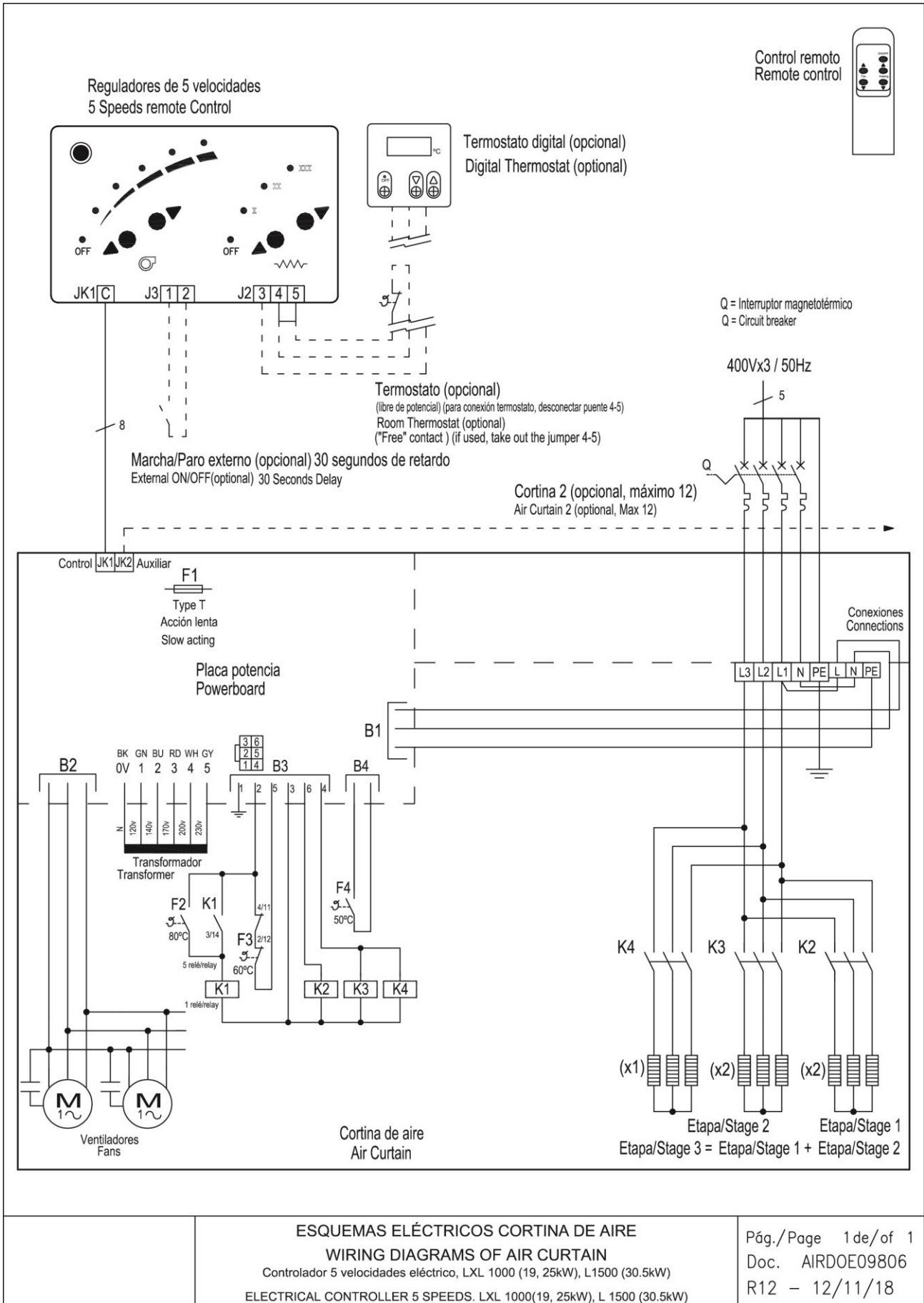

ESQUEMAS ELÉCTRICOS CORTINA DE AIRE

WIRING DIAGRAMS OF AIR CURTAIN

Controlador 5 velocidades eléctrico, LXL 1000 (19, 25kW), L1500 (30.5kW)

ELECTRICAL CONTROLLER 5 SPEEDS. LXL 1000(19, 25kW), L 1500 (30.5kW)

Pág./Page 1 de/of 1

Doc. AIRDOE09806

R12 - 12/11/18

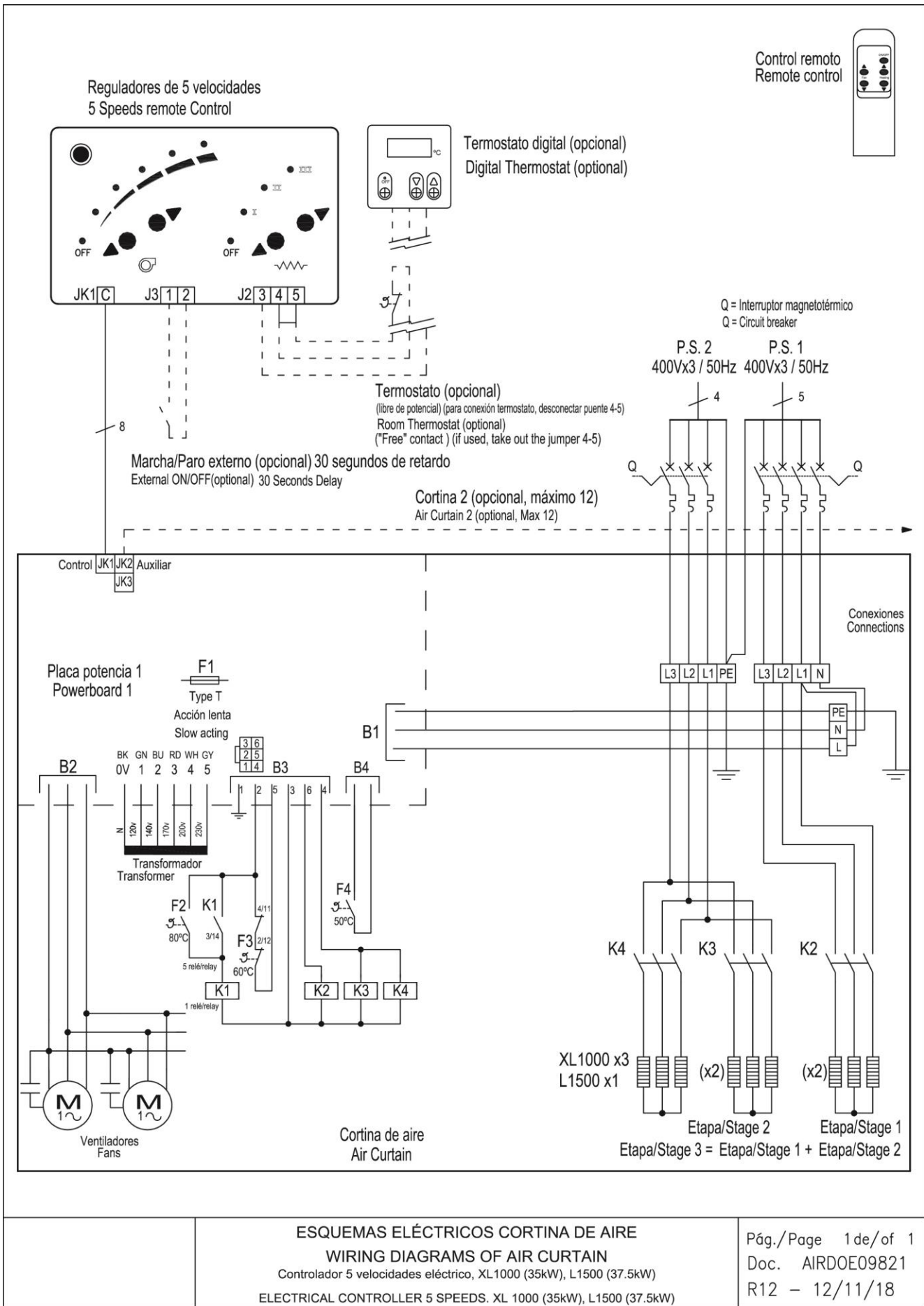

ESQUEMAS ELÉCTRICOS CORTINA DE AIRE
WIRING DIAGRAMS OF AIR CURTAIN

Controlador 5 velocidades eléctrico, XL1000 (35kW), L1500 (37.5kW)
ELECTRICAL CONTROLLER 5 SPEEDS. XL 1000 (35kW), L1500 (37.5kW)

Pág./Page 1 de/of 1
Doc. AIRDOE09821
R12 - 12/11/18

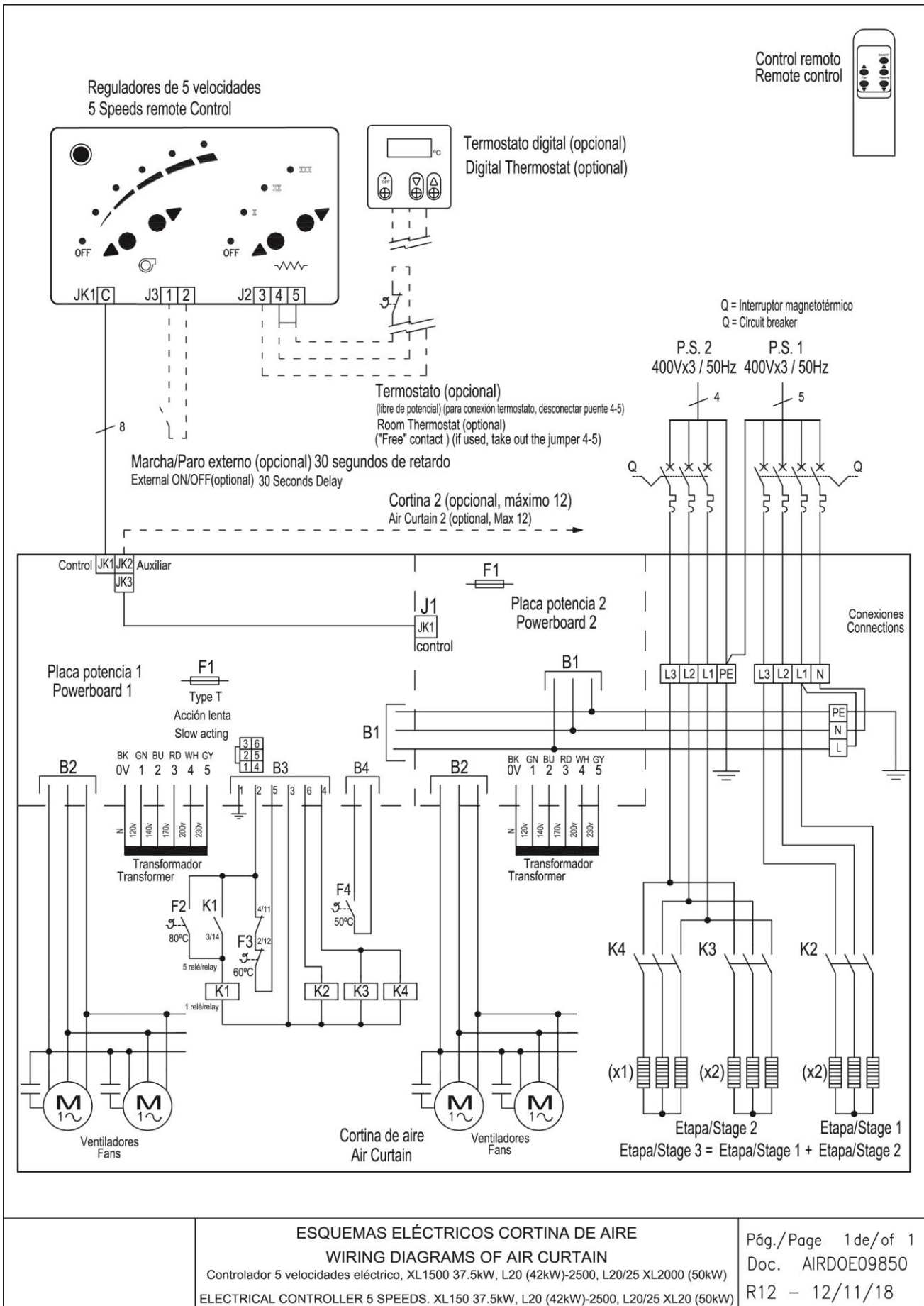

ESQUEMAS ELÉCTRICOS CORTINA DE AIRE
WIRING DIAGRAMS OF AIR CURTAIN

Controlador 5 velocidades eléctrico, XL1500 37.5kW, L20 (42kW)-2500, L20/25 XL2000 (50kW)
ELECTRICAL CONTROLLER 5 SPEEDS. XL150 37.5kW, L20 (42kW)-2500, L20/25 XL20 (50kW)

Pág./Page 1 de/of 1
Doc. AIRDOE09850
R12 - 12/11/18

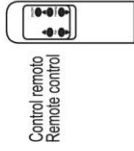

Reguladores de 5 velocidades
5 Speeds remote Control

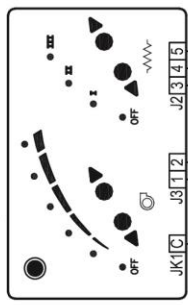

Termostato digital (opcional)
Digital Thermostat (optional)

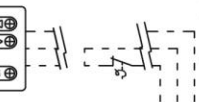

Termostato (opcional)
(línea de potencia) (para conexión termostato, desconectar puente 4-5)
Room Thermostat (optional)
("Free" contact) (if used, take out the jumper 4-5)

Marcha/Paro externo (opcional) 30 segundos de retardo
External ON/OFF (optional) 30 Seconds Delay

Cortina 2 (opcional, máximo 12)
Air Curtain 2 (optional, Max 12)

O = Interruptor magnético
Q = Circuit breaker

P.S. 1
400Vx3 / 50Hz

P.S. 2
400Vx3 / 50Hz

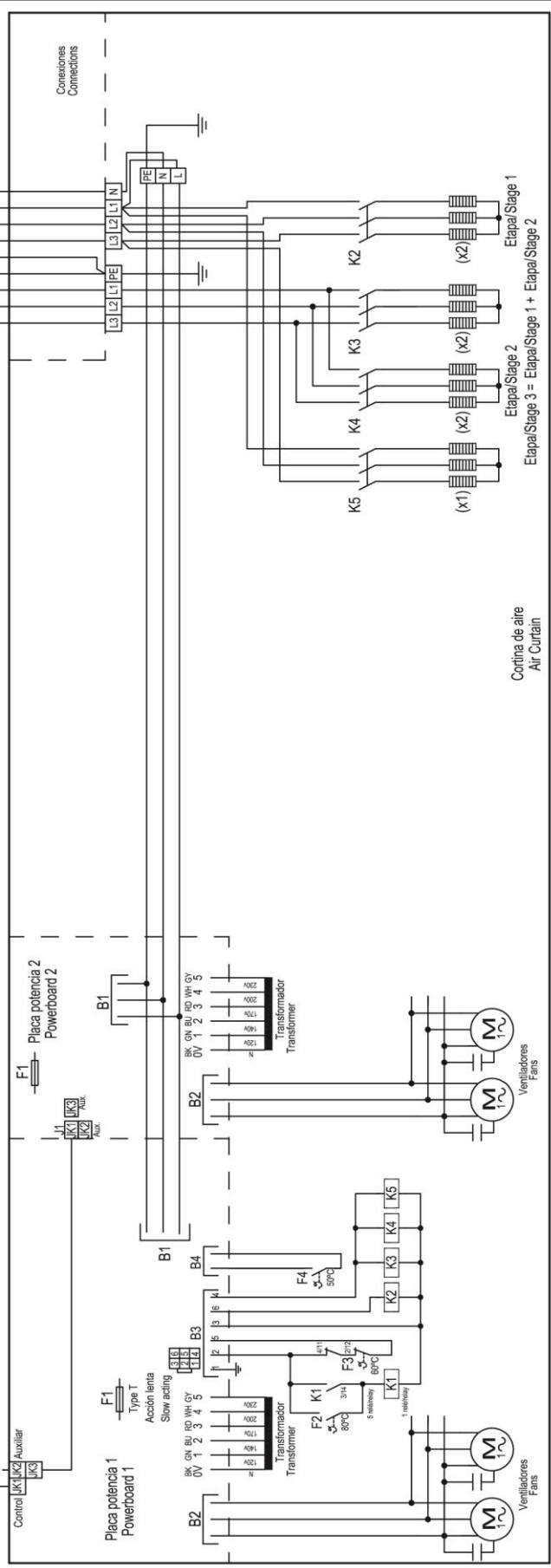

Cortina de aire
Air Curtain

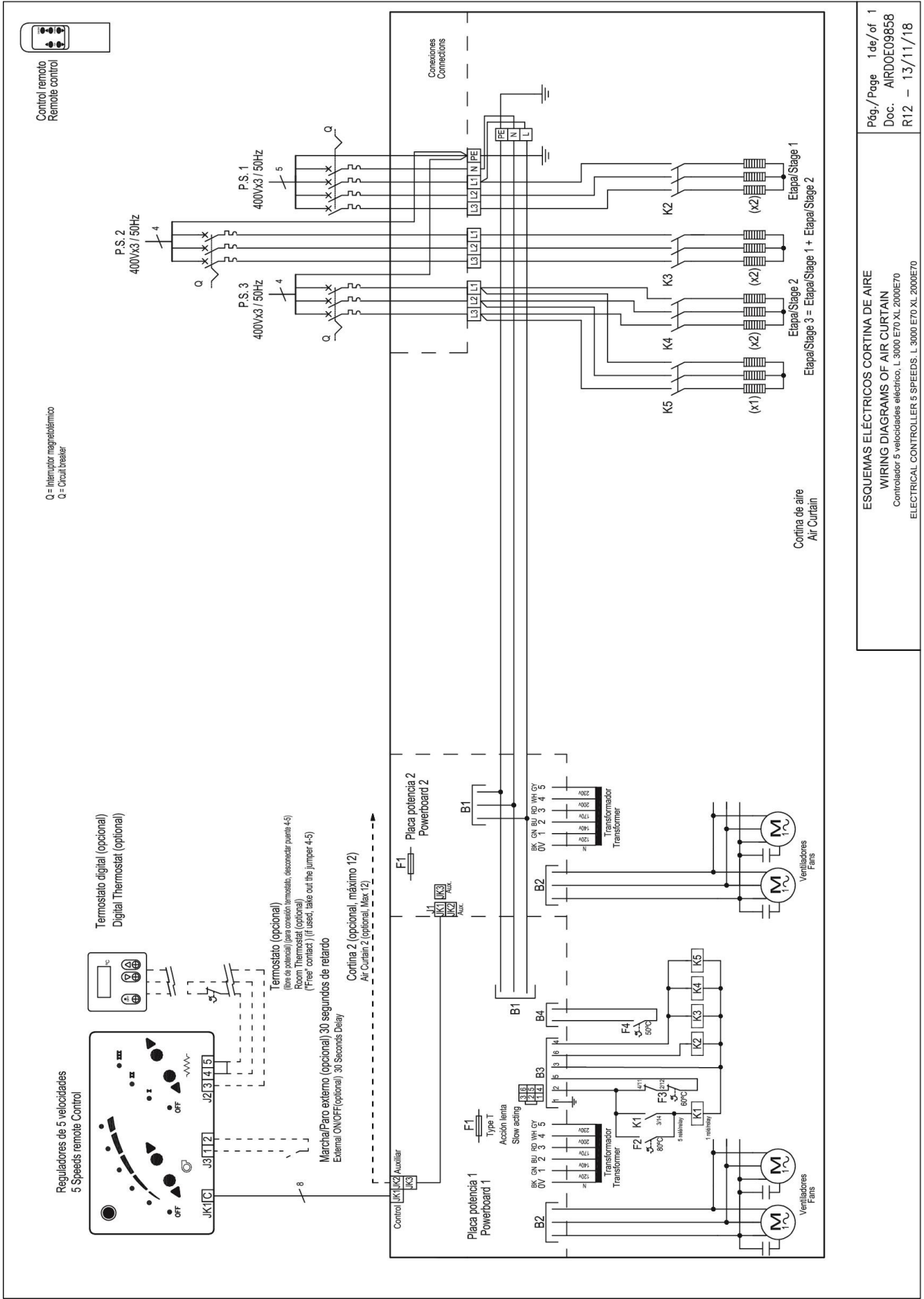

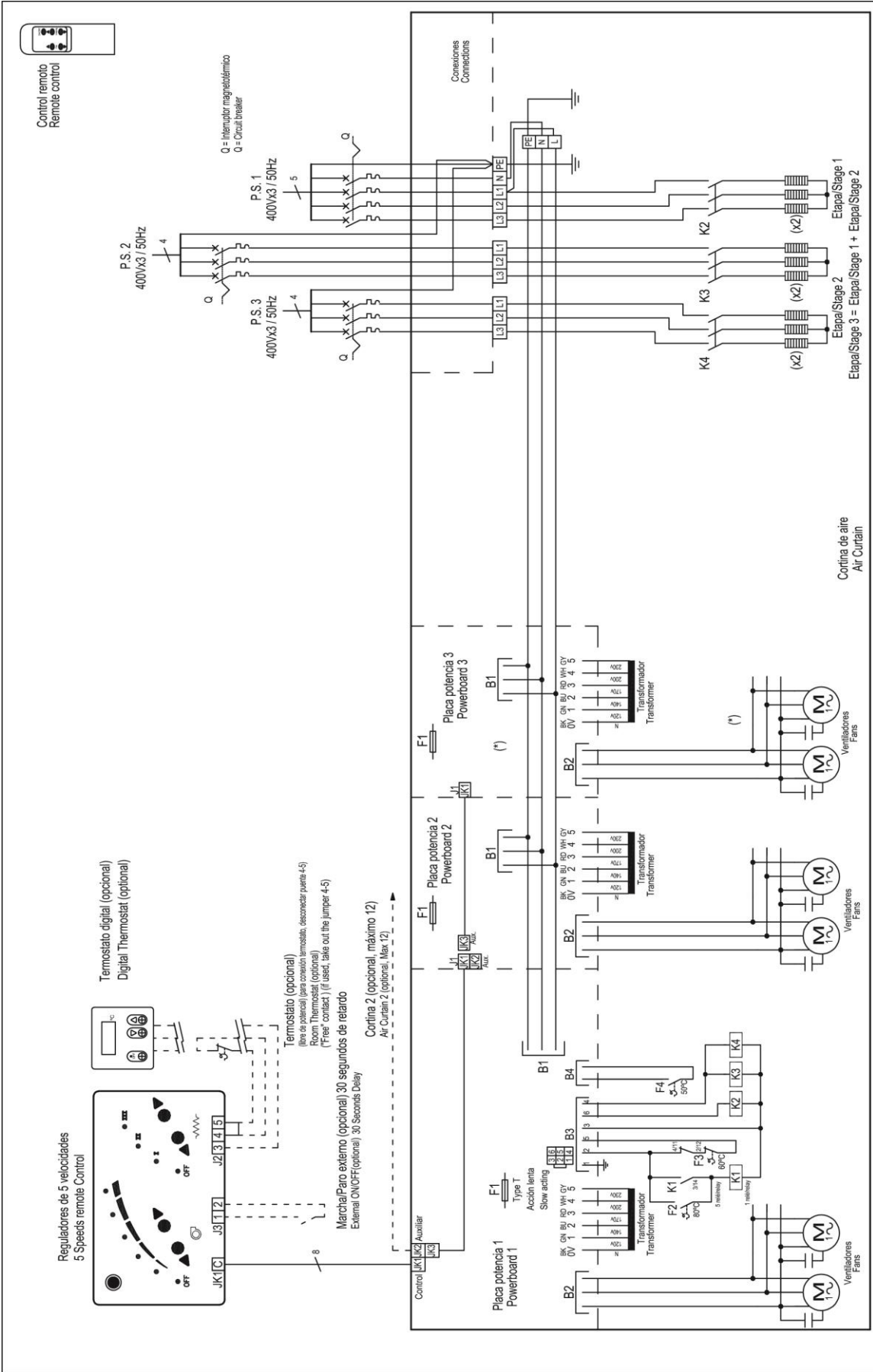

Control remoto
Remote control

Reguladores de 5 velocidades
5 Speeds remote control

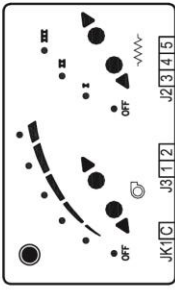

Termostato digital (opcional)
Digital Thermostat (optional)



Termostato (opcional)
(línea de potencia) (para conexión jumpers, desconectar puente 4-5)
Room Thermostat (optional)
("Free" contact) (if used, take out the jumper 4-5)

Marcha/Paro externo (opcional) 30 segundos de retardo
External ON/OFF (optional) 30 Seconds Delay

Cortina 2 (opcional, máximo 12)
Air Curtain 2 (optional, Max 12)

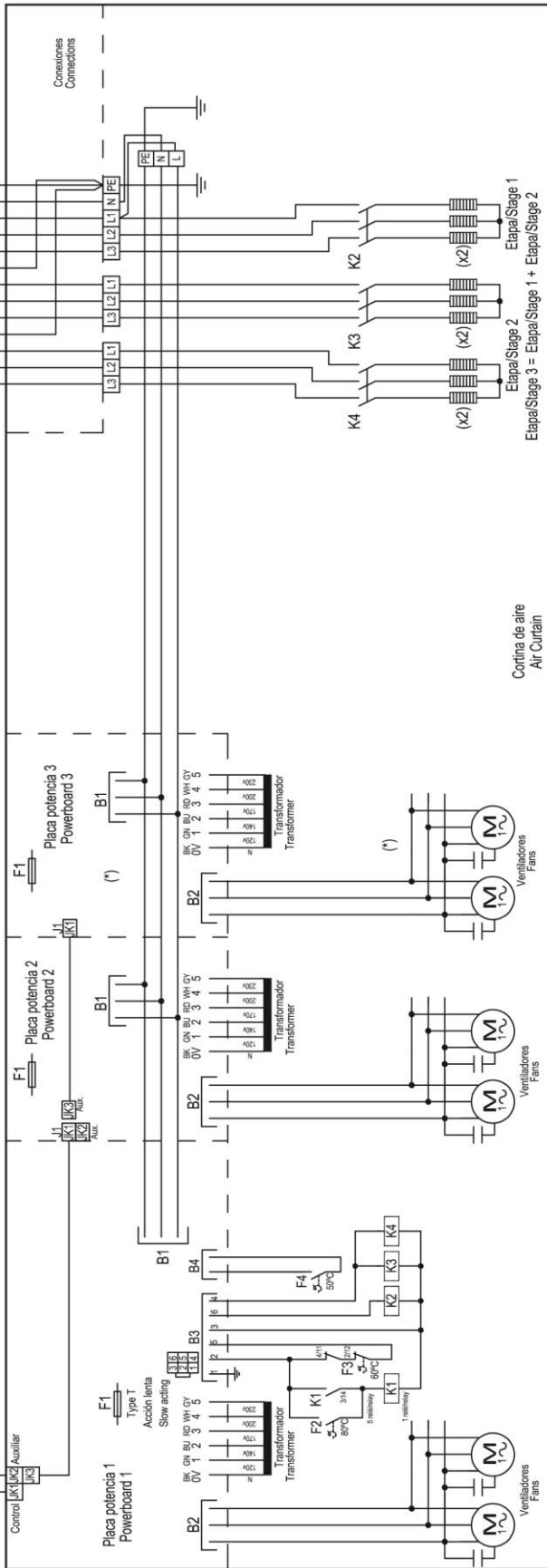

Cortina de aire
Air Curtain

(*) Placa 3 solo modelo XL2500

(*) Powerboard 3 only for model XL2500

ESQUEMAS ELÉCTRICOS CORTINA DE AIRE
WIRING DIAGRAMS OF AIR CURTAIN
Controlador 5 velocidades eléctrico, L2000-L3000-XL2500-60kW
ELECTRICAL CONTROLLER 5 SPEEDS, L2000-L3000-XL2500-60kW

Pág./Page 1 de/of 1
Doc. AIRDOE09860
R12 - 12/11/18

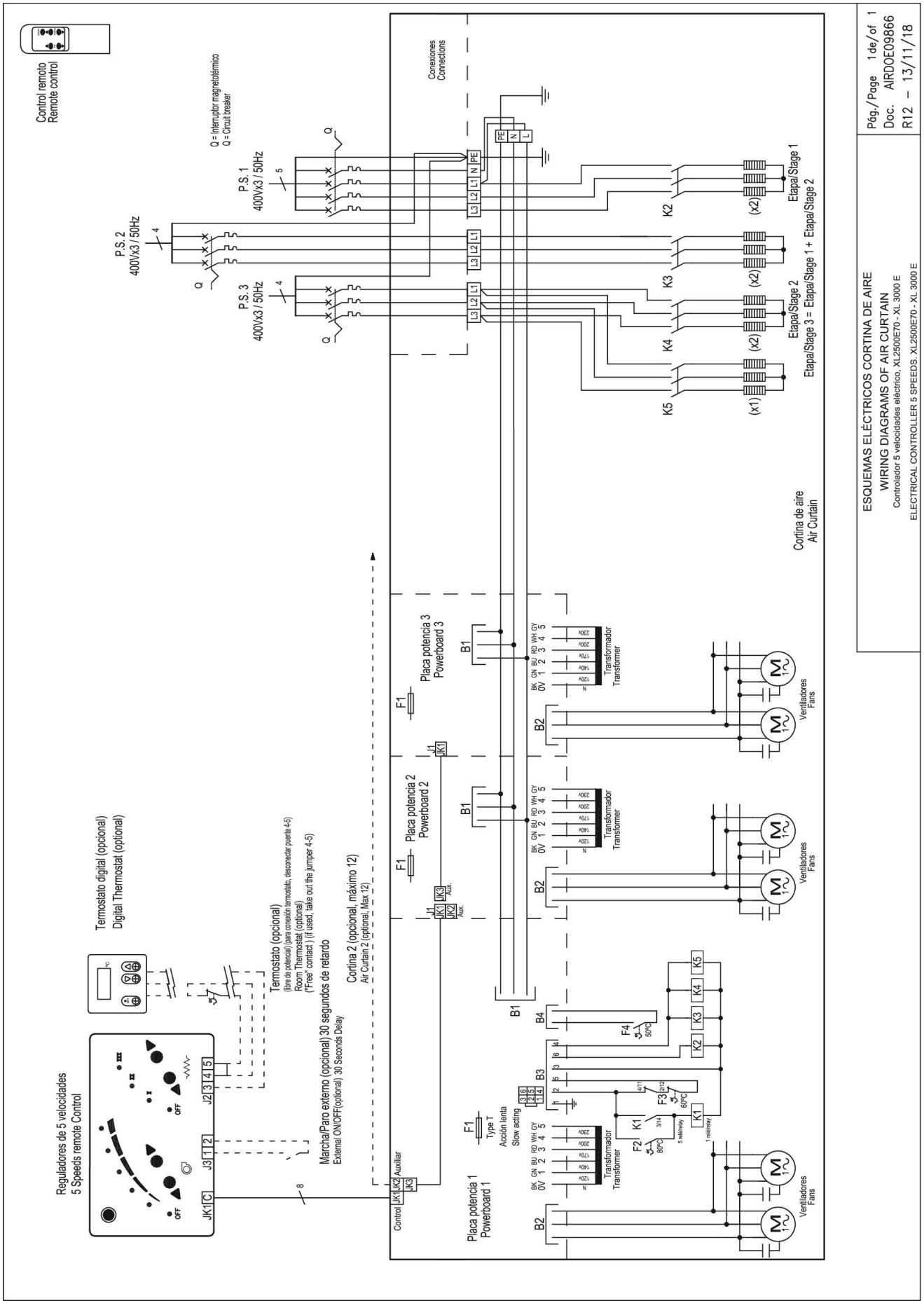

ESQUEMAS ELÉCTRICOS CORTINA DE AIRE
 WIRING DIAGRAMS OF AIR CURTAIN
 Controlador 5 velocidades eléctrico. XL2500E70 - XL 3000 E
 ELECTRICAL CONTROLLER 5 SPEEDS. XL2500E70 - XL 3000 E

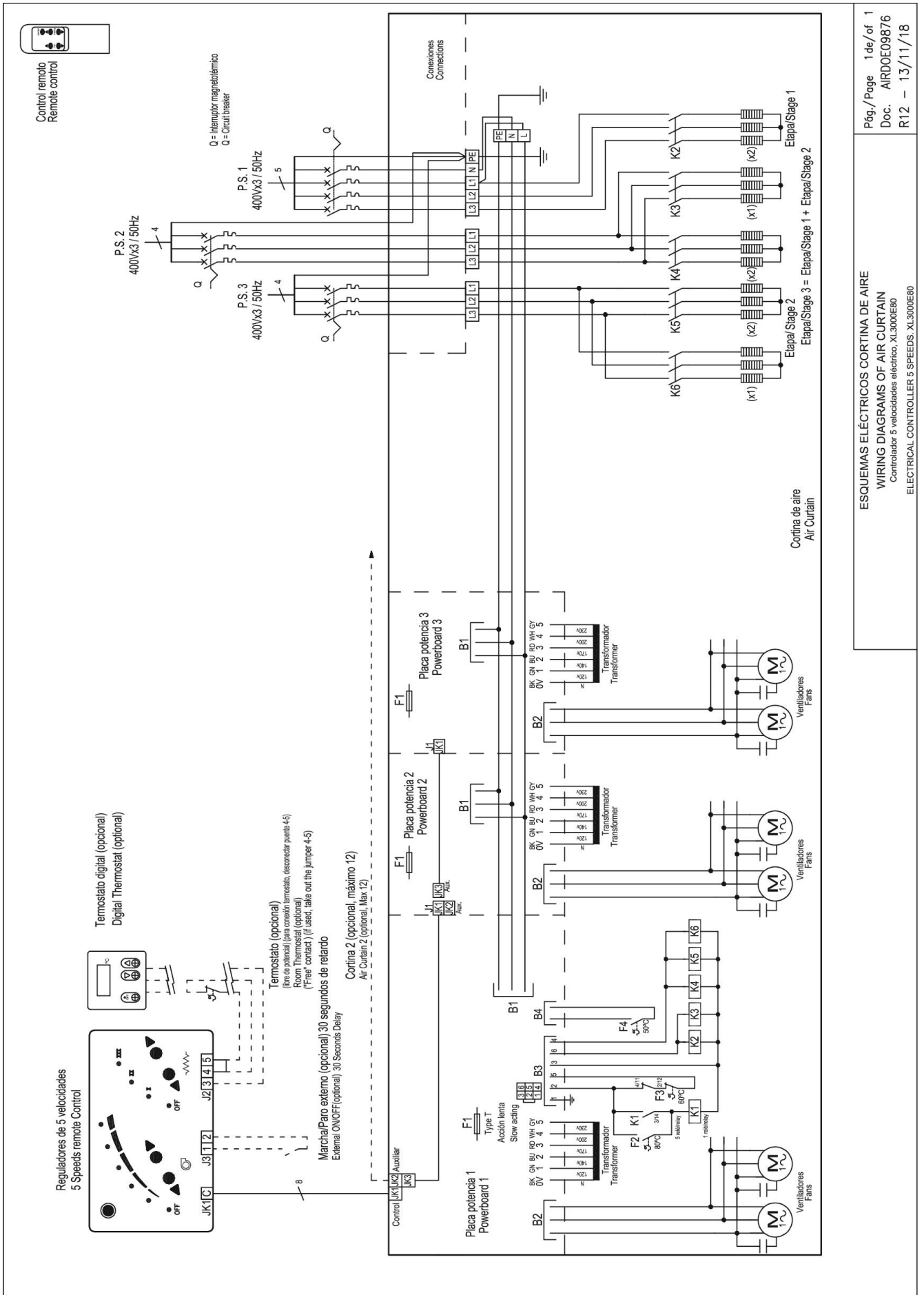

WINDBOX L,XL | High Pressure Air Curtains For Commercial And Industrial Doors



Characteristics



- Self-supporting casing construction made of galvanized steel plate, finished in structural epoxy-polyester painting white colour RAL9016 as standard. Other colours or stainless steel are available on request.
- Two frontal grille options. Industrial perforated by default.
- Anodized aluminium outlet vanes, airfoil shaped, adjustable from 0 to 15° each side.
- Double-inlet centrifugal fans driven by an external rotor motor and low noise level. 5-speed selector.
- "P" type with water heated coil. "E" type with electrical shielded elements, three stages with integrated regulation. "A" type without heating, air only. Optional expansion DX coil.
- Includes Plug&Play control with 10m RJ45 cable and infrared remote control. Optional: Clever control (programmable, automatic, intelligent, energy saving, Modbus RTU for BMS...).

Specifications

AIR ONLY

Model	Airflow m³/h	Fans Power 230V-50Hz kW	Fans Current 230V-50Hz A	Noise Level (5 m) dB(A)	Weight kg
L 1000 A	4000	1,04	4,40	63	72
L 1500 A	6000	1,56	6,60	64	108
L 2000 A	8000	2,08	8,80	65	145
L 2500 A	10000	2,60	11,00	66	177
L 3000 A	12000	3,12	13,20	67	213
XL 1000 A	5300	1,40	6,00	65	78
XL 1500 A	7950	2,10	9,00	66	117
XL 2000 A	10600	2,80	12,00	67	157
XL 2500 A	13250	3,50	15,00	68	192
XL 3000 A	15900	4,20	18,00	69	211

ELECTRICAL HEATED

Model	Airflow m³/h	Electrical Heating Capacity 400Vx3-50Hz kW	Fans Power 230V-50Hz kW	Fans Current 230V-50Hz A	Noise Level (5 m) dB(A)	Weight kg
L 1000 E	4000	10/15/25	1,04	4,40	63	90
L 1500 E	6000	15/22,5/37,5	1,56	6,60	64	135
L 2000 E	8000	20/30/50	2,08	8,80	65	180
L 2500 E	10000	20/40/60	2,60	11,00	66	225
L 3000 E	12000	20/40/60	3,12	13,20	67	270
XL 1000 E	5300	10/15/25	1,40	6,00	65	95
XL 1000 E-35	5300	10/25/35	1,40	6,00	65	96
XL 1500 E	7950	15/22,5/37,5	2,10	9,00	66	144
XL 1500 E-52	7950	15/37,5/52,5	2,10	9,00	66	150
XL 2000 E	10600	20/30/50	2,80	12,00	67	192
XL 2000 E-70	10600	20/50/70	2,80	12,00	67	200
XL 2500 E	13250	20/40/60	3,50	15,00	68	240
XL 2500 E-70	13250	20/50/70	3,50	15,00	68	250
XL 3000 E	15900	20/40/60	4,20	18,00	69	288
XL 3000 E-80	15900	30/50/80	4,20	18,00	69	300

WATER HEATED

Model	Airflow m³/h	P86		P64		P54		Fans Power 230V-50Hz kW	Fans Current 230V-50Hz A	Noise Level (5 m) dB(A)	Weight kg
		Heating Capacity 80/60°C kW	Water Drop Pressure 80/60°C Pa	Heating Capacity 60/40°C kW	Water Drop Pressure 60/40°C Pa	Heating Capacity 50/40°C kW	Water Drop Pressure 50/40°C Pa				
L 1000 P	3800	19,68	1730	16,18	2570	17,18	1560	1,04	4,40	62	89
L 1500 P	5700	29,64	950	25,92	3210	29,04	5710	1,56	6,60	63	128
L 2000 P	7600	43,01	2390	35,58	3680	38,93	4330	2,08	8,80	64	171
L 2500 P	9500	56,01	4670	45,55	4750	49,36	4990	2,60	11,00	65	214
L 3000 P	11400	69,27	8090	56,78	8350	59,96	5770	3,12	13,20	66	260
XL 1000 P	4900	22,68	2250	18,98	3410	20,43	2120	1,40	6,00	64	94
XL 1500 P	7350	34,52	1240	30,45	4270	34,55	7780	2,10	9,00	65	137
XL 2000 P	9800	50,10	3140	41,83	4910	46,36	5910	2,80	12,00	66	183
XL 2500 P	12250	65,29	6130	53,56	6330	58,81	6810	3,50	15,00	67	227
XL 3000 P	14700	80,79	10640	66,78	11140	71,47	7890	4,20	18,00	68	278

Water heated: P86 2 rows coil, P64 3 rows coil, P54 4 rows coil.
2x1" for 1000 and 1500, 2x1½" for 2000 and 2500, 2x1½" for 3000.
Connection pipes P86, P64 and P54 are female (male if lateral pipes).



Layouts and dimensions



Free hanging mounting

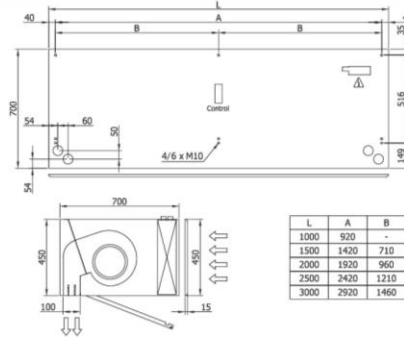

Inside ceiling surface mounting

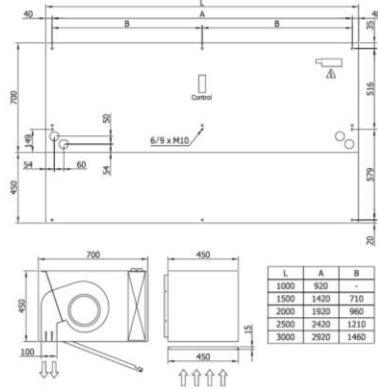

False ceiling invisible mounting

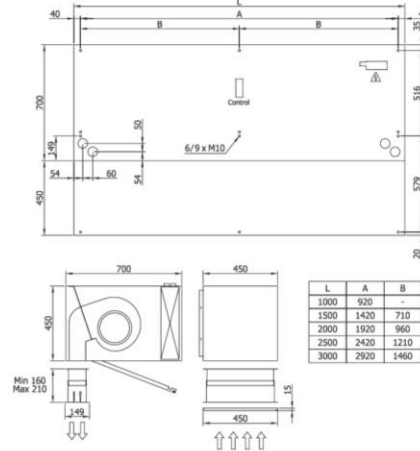

Grille Finishes



Industrial

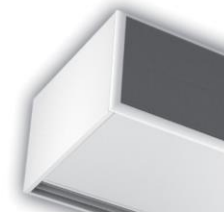
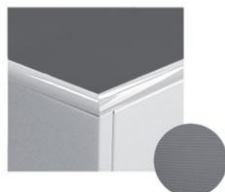

Decorative



MAINTENANCE INSTRUCTIONS

	<i>For safety, before any cleaning, disconnect power supply using the controller.</i>
	<i>It is forbidden to open the service door (risk of electrical discharge and being trapped in fans). Service and maintenance should be done only by introduced and qualified workers.</i>
	<i>Do not use water or steam for cleaning the internal parts and components of the air curtain.</i>

External cleaning

Air curtains don't need any kind of maintenance except from the cleaning of the casing and the inlet grille. It is recommended to weekly clean the inlet grille. It's important to make sure that the air curtain is OFF, otherwise the dust mixed with a wet cloth would create a kind of paste that will damage the fan rotor when it sucks the air.

Annual cleaning of the discharge area (outlet).

The casing of the air curtain should be cleaned with a wet cloth and non-aggressive detergent. Do not use caustic soap or acids.

The inlet grille prevents the settling of dust and strange objects in the internal elements. It is recommended to check periodically that the inlet grille is free of any object that could interfere the air entrance (plastic bags, papers, etc.).



Internal cleaning

In models without micro drilled inlet grille and water coil or electrical heating is recommended to clean the inside of the unit with a vacuum at least once a year (*), best before the winter season, with qualified staff.

(*) These periods are indicative, depending on the ambient conditions of every installation.

In places with a high number of particles in suspension is desirable to increase the frequency of the internal cleaning (including the city centers, near construction sites, etc.).

REPAIRS AND REPLACEMENTS



Installation and electrical connections must be done by qualified workers and following these instructions.

Before any repairs are undertaken, please:



- **Inform people that there is work in progress.**
- **Disconnect the power supply and protect the thermal magnet (so nobody can restart it accidentally).**
- **Make sure there is no tension in the air curtain.**
- **Make sure the fans are stopped.**
- **Use only original spare parts.**



To **open the service door**, follow these steps:

1.- With a screwdriver and holding the door, remove all the screws that fix the door.



2.- Open the door carefully. In case of an air curtain with **plenum or inlet/outlet kits** the lever we must do it from the side of the door where there is an oblong, to make it easier the entrance of a flat screwdriver.



Fan replacement

Before replacing the fan, inform people that there is work in progress, stop the air curtain through the controller and disconnect main supply. Make sure that the unit is without tension and the fans are stationary.

L: Identify the fan cables and unplug the fan from the cable tree. Remove the fan by loosening the fixing screws and assemble the new fan following the process in reverse order.

XL: Identify the fan cables and unplug the fan from the cable tree. Remove the fan by loosening the fixing screws of the platform (Photo 2) to remove the air curtain (Photo 1), remove the screws of the fan and assemble the new fan following the process in reverse order.



Photo 1



Photo 2

Fuse and PCB replacement

Before the replacement, inform people that there is work in progress.

Disconnect main supply, make sure that the unit is without tension and that the fans are stationary.

Fuse replacement: Open the service door and remove the fuse of the fuse holder by hand or pulling with the help of a screwdriver pressing to the plate and turning in under clockwise, then replace it.

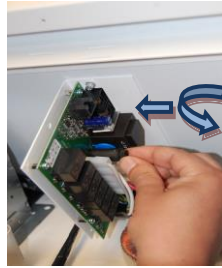

PCB replacement: Open the service door and simply unscrew the power plate from the inside of the air curtain to remove it and make the necessary repairs.



Heater replacement

Before the replacement, inform people that there is work in progress, disconnect main supply, make sure that the unit is without tension and that the fans are stopped. Before proceeding to unfasten the heater fixing screws, we must:

Water Coils: Close the shut-off water valves of the building water circuit to the air curtain (supply and return). Open the service door and empty the water from the coil simply removing the draining screw placed in the bottom of the entrance manifold as shown in the photograph.



Electrical Heaters: Disconnect the power supply from the electrical element.

When we have the coil or heater ready, we proceed to remove the fixation screws to disassemble the coil or heater and assemble the new heater following the same process in reverse order.



Remove the screw-earth of the connection box and disassemble from the equipment.



Unplug the cables to 1, 2, 3 in the connection box.

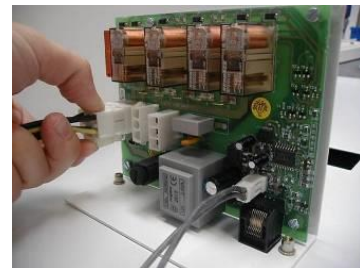

Unplug the two connectors of plate pressing the fluke.

Fixation points of coils and heaters: Angle closes door and interior angles.



FAILURES AND SOLUTIONS

More than 95% of the complaints are submitted during the start of operation of the equipment and are due to installations errors.

More than 90% of the failures are solved only by **checking the connections**. Following the three following points, we can make sure that the installation is correct:

A) RJ45 cable manipulated: The cable that connects the controller to the air curtains is an 8 lines crossed RJ45 cable. **If manipulated (cut or removed the connector) and incorrectly joined (reverse way) the air curtain will not work well.** Moreover it can damage the electronics. To solve the problem just turn the connector of the cable (see connection diagram in the first page).

B) Wrong connection of the RJ45 cable. Verify whether the connector position is the correct, between the “control” and “auxiliary”, according to the installation diagram (particularly if there are several air curtains with a single controller).

C) Wrong current supply/input. The air curtain input depends on the type of current available and also on the heating type of the unit. Connect the unit according to the connection diagrams of the first page.

More common failures and solutions		
Effect	Problems	Solutions
All lights of the controller are OFF	Is the RJ45 cable the original (not manipulated), with no enlargements either shortenings?	Change the cable or connect it again correctly.
	Does the current reaches the connection box?	Connect correctly the terminals of the junction box: Between L and N there must be 230V and if the air curtain goes with three-phase electrical element, there must be 400V among terminals L1, L2 and L3.
	Is the controller connected to the air curtain, to the connector “Control” of the PCBoard?	Connect the cable from the controller to the “Control”, never to the “Aux”.
	Is the fuse of the PCBoard in good conditions?	Check the fuse and replace it in case it is necessary (type T, slow action).
Some lights of the controller are Flashing.	The green LED of the maximum speed flashes when we stop the air curtain after having been operating with heating.	It is not a failure, but a safety mechanism. The air curtain turns on by itself to the maximum speed to get cold and protect its components. When it decreases from the safety temperature, it will stop.
	Some speed or heating lights are flashing when the air curtain is working.	It is a protection mechanism of the air curtain so that the internal parts of the air curtain do not suffer damages. Situations on which the problem continuously recurs and the way to solve it: 1. Inlet grille blocked (objects, dirtiness...) the ambient temperature inside the equipment can increase a lot if the air cannot circulate. Clean the grille. 2. Small room: we recommend installing a thermostat to control the heating power so the protection device do not activates. 3. In case that the ambient temperature is already high, we recommend to lower the power heating or install a thermostat. 4. Inlet air already warm, that comes from another heating equipment beyond the air curtain. Move the air curtain away, place a thermostat in the inlet part of the curtain or lower the heating power. 5. Any motor does not work: call the technical service.
The heating does not work	Does the three-phase current reach the connections box?	Check installation.
The speed and/or the heat changes continuously with no apparent reason but the lights of the controller are not flashing.	Probably the RJ45 cable is near interference sources, transmitters, cable plates, particularly those that supply current to Motors, etc.	Pass the cable the furthest possible away from interference sources, particularly when long distances or use a screened table.

ACCESSORIES



Clever Control

Intelligent proactive regulation, advanced functions, Automatic/manual working, door delay, timer, save energy program, multi equipment management, BMS Modbus connection, etc.



External temperature Sensor

It permits to take the temperature from a place different to the control.



Interface II

Allows the connection to a centralized management system (BMS, PLC, etc.).



Hand Auto 5 Speed (water heated)

It permits to connect anti-freezing sensors, door contact, ambient thermostat, etc.



Ambient Thermostat

It limits the operating of the heating to the selected one.

Supports, feet, vibration dampers, etc. depending on the model.

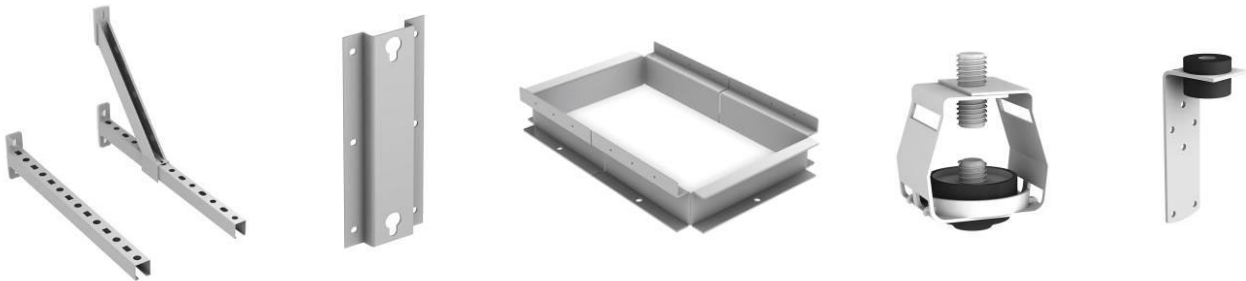

Door contact, thermostatic valve, solenoid valve, antifreezing sensor, etc.



RJ45 Cable 20m and 50m



Plenum and/or inlet/outlet kit (depending on the model)



DECLARATION OF CONFORMITY



Declaration **CE** of conformity / Declaración **CE** de conformidad

Manufacturer **Motors i Ventiladors S.L. (AIRTÈCNICS)**
Fabricante **Conca de Barberà 6, Pol. Ind. Pla de la Bruguera**
08211 Castellar del Vallès (Barcelona) Spain

We declare, under our sole responsibility, that the product(s)
Declaramos, bajo nuestra única responsabilidad, que el/los producto(s)

Air Curtains
Cortinas de aire

with models
con los modelos

Minibel, Optima, Recessed Optima, Windbox, Recessed Windbox, Smart, Dam, Deco, Kool, Variwind, Rotowind, Invisair, Rund, Zen, Duojet, Triojet, Max, Recessed Dam, Recessed Compact, Maxwell

is/are developed, designed and manufactured in accordance with the following directive(s)
ha(n) sido desarrollado(s), diseñado(s) y fabricado(s) de acuerdo con la(s) siguiente(s) directiva(s)

Low Voltage Directive 2014/35/UE
Directiva Baja Tensión 2014/35/UE

Electromagnetic Compatibility Directive 2014/30/UE
Directiva Compatibilidad Electromagnética 2014/30/UE

Restriction Certain Hazardous Substances Directive 2011/65/EU (RoHS)
Directiva Restricción Substancias Peligrosas 2011/65/EU

Eco-design Energy-related Products Directive 2009/125/EC
Directiva Diseño Ecológico Productos Con Energía 2009/125/CE

applying the following harmonized standards in particular
aplicando las siguientes normas armonizadas en particular

LVD: EN 60335-1:2012 + AC:2014 + A11:2014
EN 60335-2-30:2010 + A11:2012

EMC: EN 61000-6-2:2006
EN 61000-6-3:2007 + A1:2012
EN 55014-1:2008 + A1:2009 + A2:2012
EN 55014-2:2015

RoHS: EN 50581:2012

Date / Fecha
Name / Nombre
Position / Cargo

03/05/2016
Jordi Oltra Orta
General Manager / Director General





Model <i>Modelo</i>	WINDBOX M 2000 E			
Airflow <i>Caudal</i>	3600	m3/h		
Blowers <i>Ventiladores</i>	1,88	A	0,424	kW 230 V/50Hz
Heating capacity <i>Calefacción</i>	80/60 °C		60/40 °C	
Water Coil <i>Agua</i>		kW		kW
Electric Coil <i>Batería Eléctrica</i>	6/12/18	kW	400V~3 50Hz	
Serial Number <i>Número de Serie</i>	2015-07-06 / 61.990			

Air curtain identification

Each air curtain is identified by a unique serial number printed in a label located inside the door service. There is also indicated the model and their technical characteristics (flow, fans technical characteristics and power heating).

It is indispensable to have this number to facilitate possible replacements or technical information of the air curtain in question.

If you detect some error in this manual, we'll be pleased to receive your *feedback*, it helps us to improve even more.

Airtècnics reserves the right to modify some of the specifications in this manual.

GUARANTEE

Your air curtain is guaranteed for a period of one year from the date of purchase. We will adjust, repair or replace at our discretion from our warehouse any defect, system failure or part found to be defective. The assembly cost out of our warehouse is at buyer expense. The products that, in our eyes, have been inadequately used, incorrectly manipulated, improperly installed, connected to different nominal tensions, modified, repaired by non-authorized workers or that have suffered damages during transport are totally excluded from the guarantee.

To validate the guarantee it should be correctly filled and enclosed with the invoice that vouches for the buying date. If it is manipulated, it will lose all validity.

It is the buyer's responsibility to take the necessary safety measures because in case of a failure or mistake in one of our products, no damages to third parties, sets or installations will occur.

✂ -----

Guarantee draft

Air curtains data:

Model: Series number:
 Invoice date: Invoice number:

Buyer data:

Name:
 Address:
 Country: Phone: Fax:

Seller data:

Name:
 Address:
 Country: Phone: Fax:

Buyer signature and stamp

Seller signature and stamp