



PARTNER  
IN VENTILATION  
2VV.CZ

EN

# ESSENSSE NEO COMFORT V3



**Installation and operation instructions**

CE EAC

## CONTROL THE DELIVERY

### PLEASE NOTE

Check the product for damages immediately after delivery. In case of damage on the packaging, contact the carrier. Claims not filed in due time will be disregarded.

- Check that it corresponds to the type of product ordered. In case of discrepancy, do not unpack the product and contact the vendor.
- After unpacking, check that the product and all the other components are in good order. In case of doubt, contact the vendor.
- Do not install a damaged unit!
- If you will not unpack the product immediately after delivery, store it indoors, in a dry place with ambient temperatures between **+5 °C and +40 °C**.



	<p>All the packaging material is environmentally friendly and can be reused or recycled. Contribute actively to the protection of the environment and ensure the proper disposal or recycling of the packaging materials.</p>	
--	---	--

## PACKAGE CONTENTS

### COMFORT MASTER

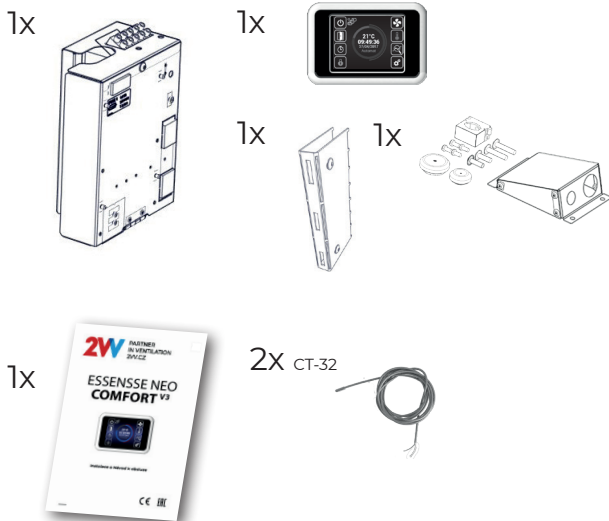

### COMFORT SLAVE

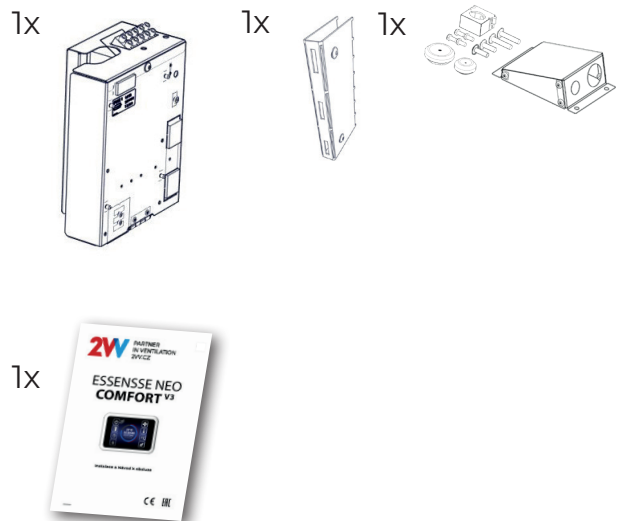

### PLEASE NOTE

- If the unit was transported in temperatures lower than 0°C, after unpacking, leave it in operational conditions for at least two hours without activating in order to compensate the inner temperature.

# 1. INSTALLATION

## 1.1 CONNECTING THE CONTROL MODULE TO THE AIR CURTAIN

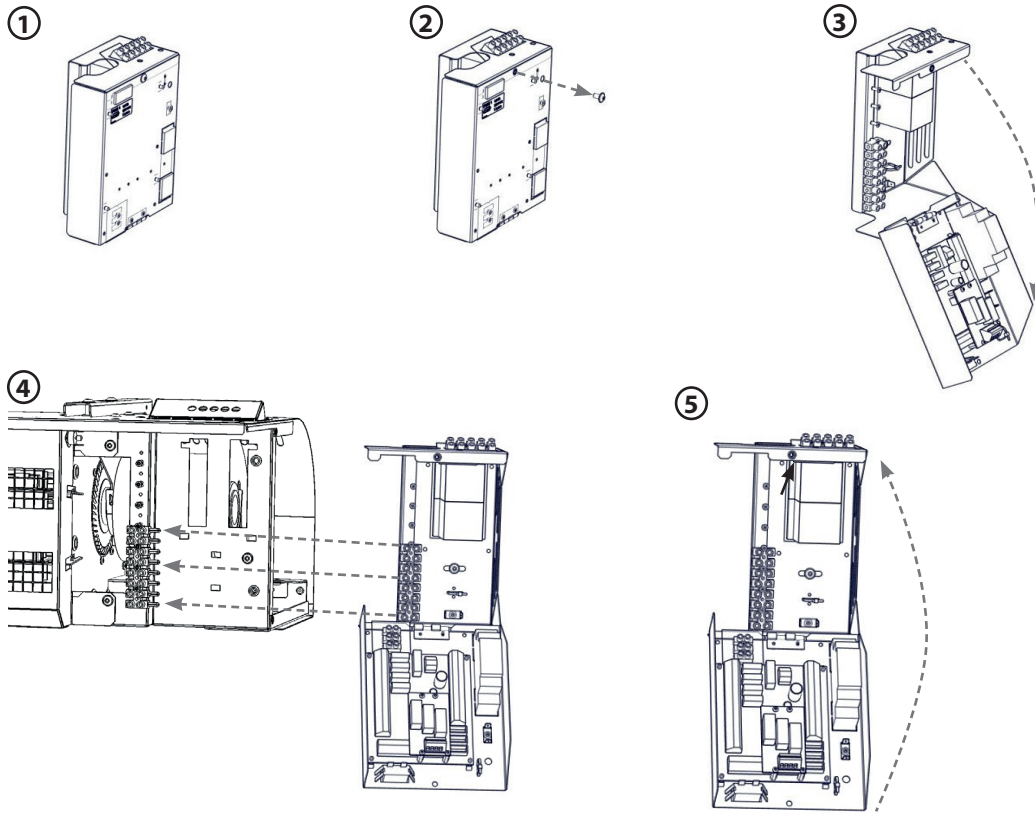

## 1.2 CONNECTING THE CONTROL

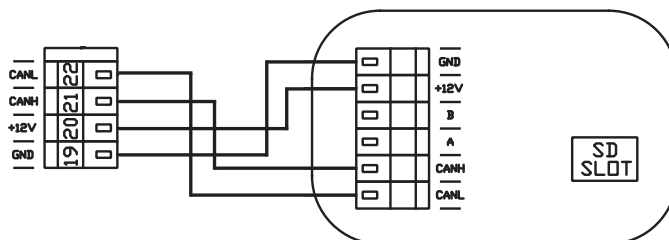
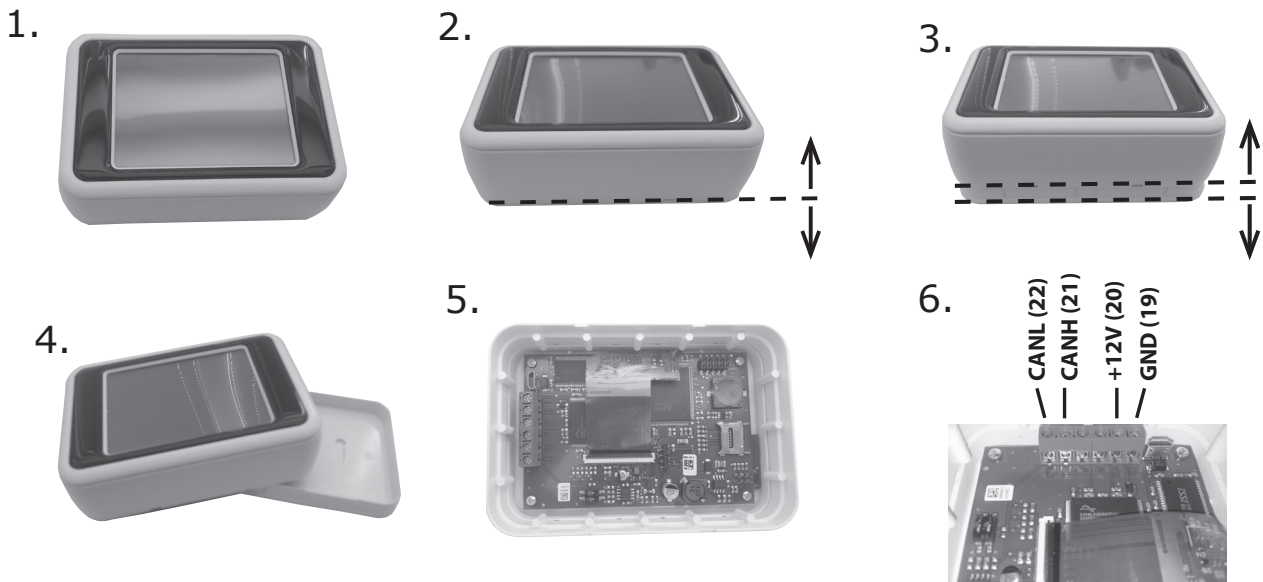

# 1. INSTALLATION

## COMFORT MASTER

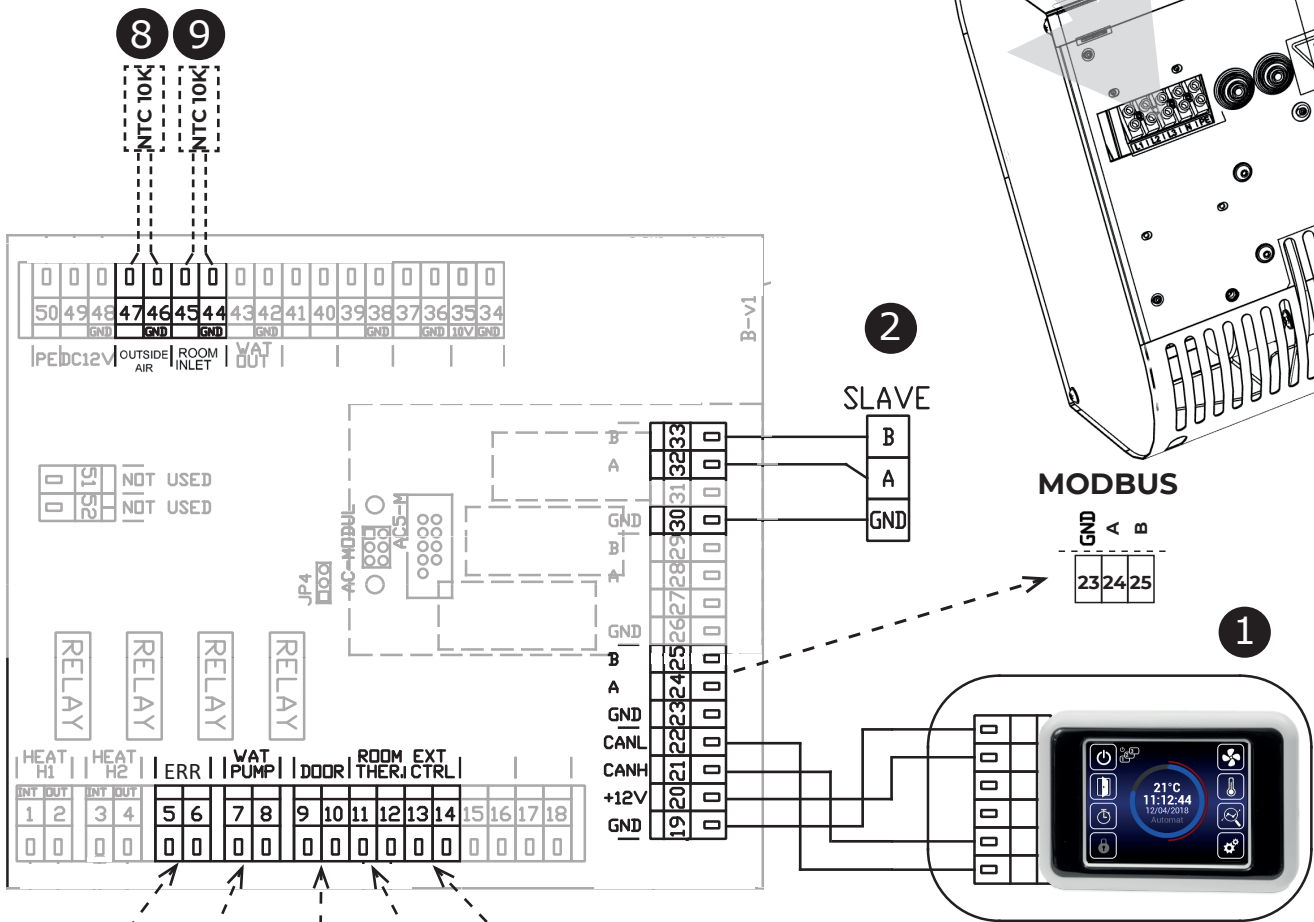
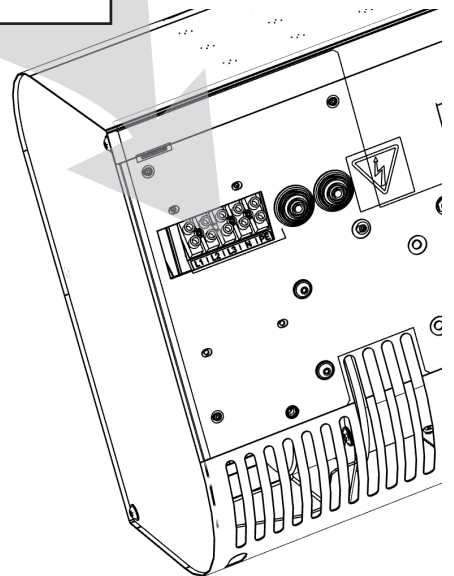
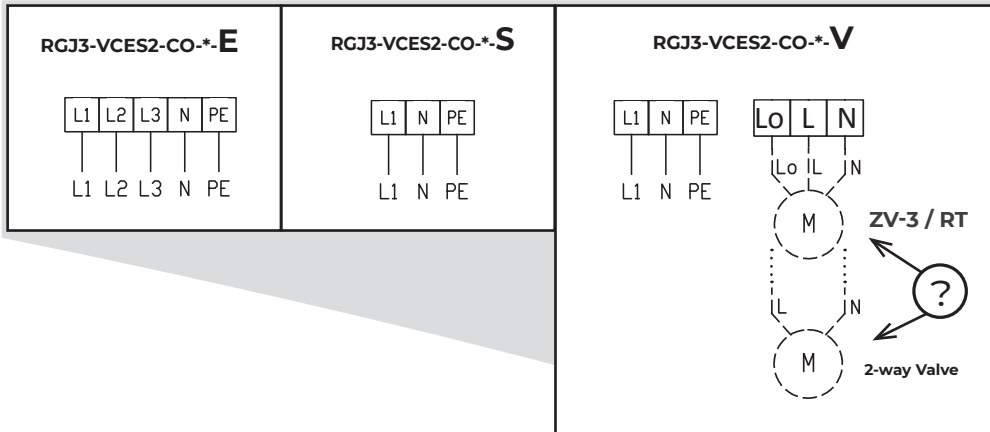

1	Control panel
2	Signal to SLAVE unit
3	ERROR contact (relay contact, NO/NC)
4	Water pump (relay contact)
5	DOOR contact (input, NO/NC)
6	Room thermostat (input, NO/NC)
7	External control (input, NO/NC)
8	Outside air (include delivery)
9	Room sensor (include delivery)

# 1. INSTALLATION

## COMFORT SLAVE

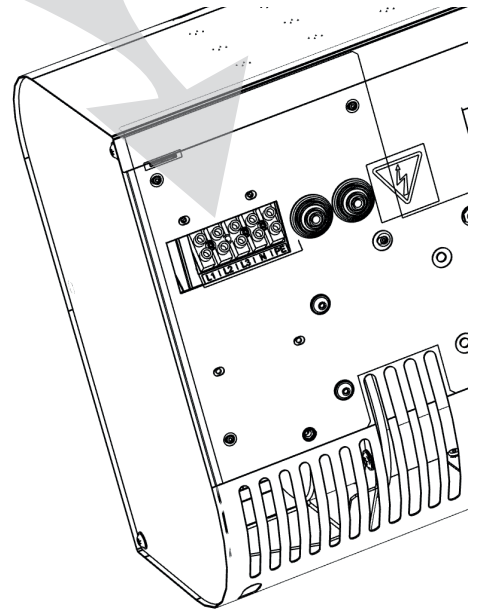
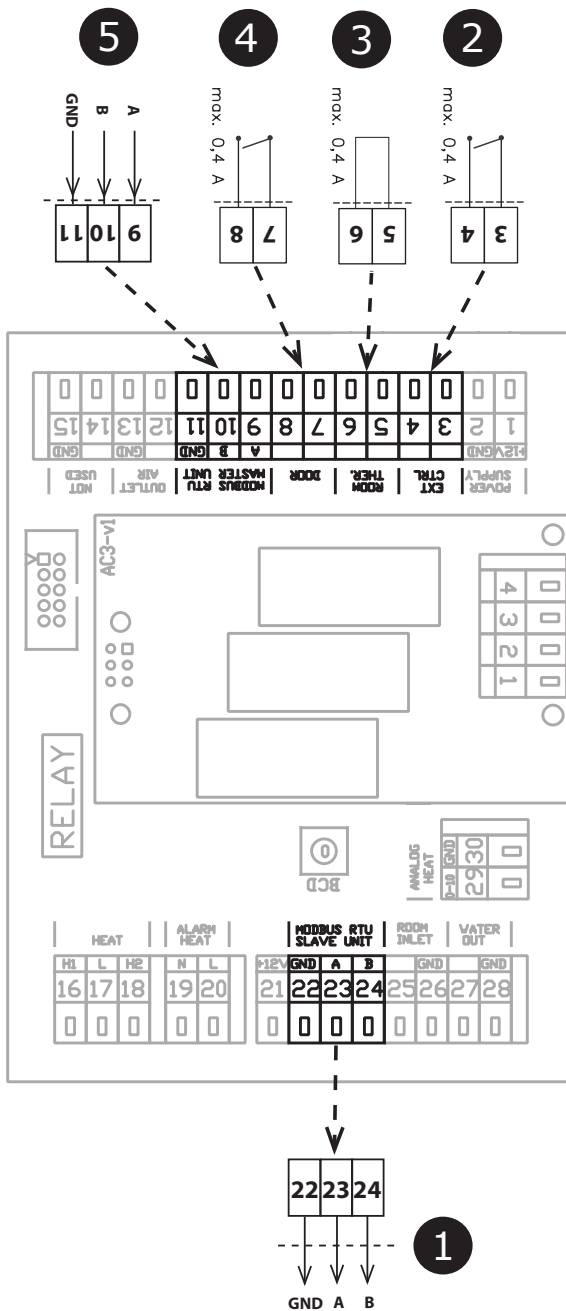
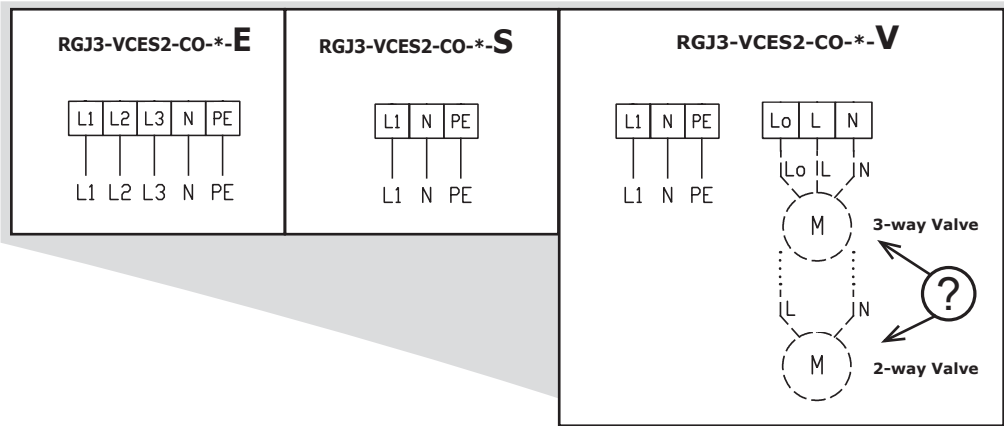

1	Connection for SLAVE unit
2	External control (input, ON/OFF)
3	Thermostat (input, NO/NC)
4	DOOR contact (input, NO/NC)
5	Control signal from MASTER unit

# ELECTRICAL SCHEMES CHAINING

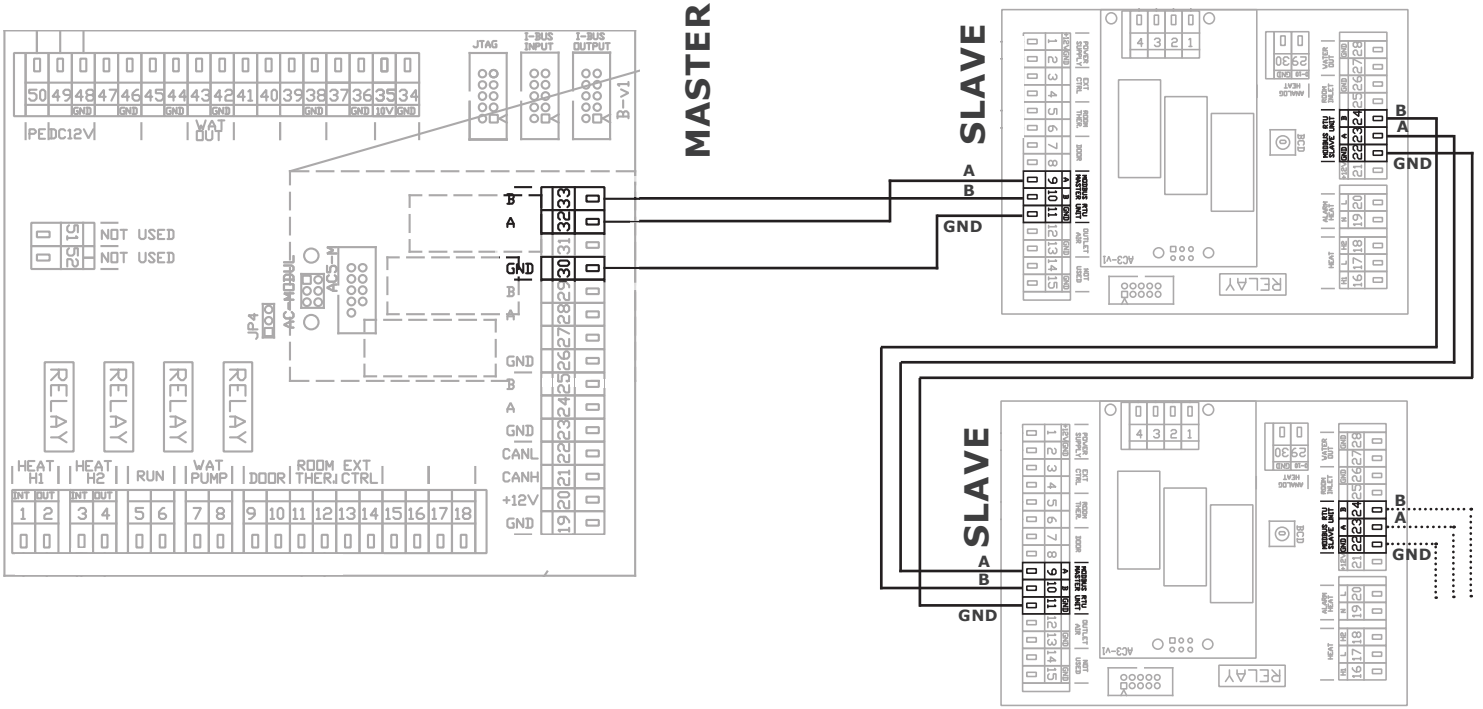
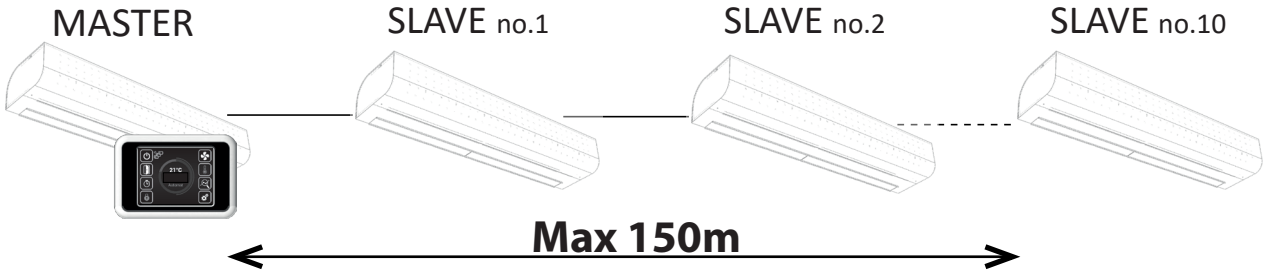

The total bus length of all chained curtains must not exceed 150m!!!

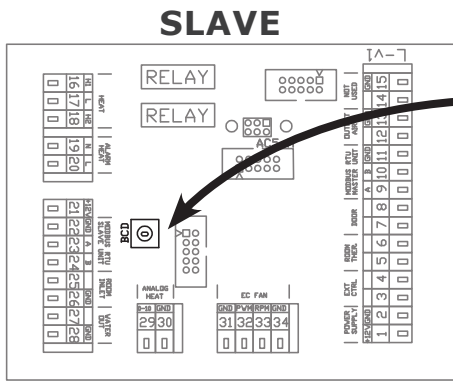

SLAVE	BCD	SLAVE	BCD
NO.1	1	NO.6	6
NO.2	2	NO.7	7
NO.3	3	NO.8	8
NO.4	4	NO.9	9
NO.5	5	NO.10	A

# 1. INSTALLATION

Location of temperature sensors

Room Temperature Sensor - Accessories

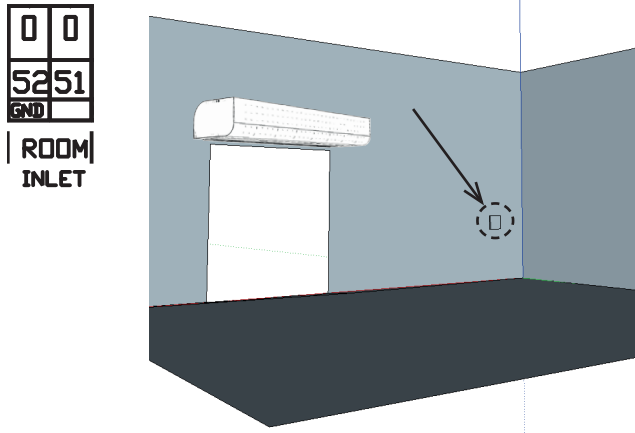

Outdoor temperature - the sensor is included

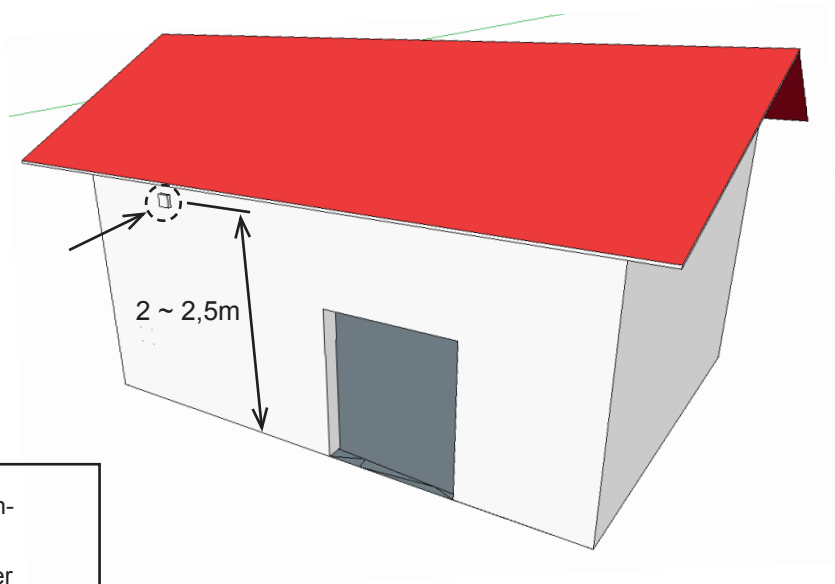

	<p>The outdoor temperature sensor is recommended to be installed on the north side of the building, protected from direct sunlight or other undesirable thermal radiation.</p> <p>The temperature sensor is recommended to be installed in a cover box that should contain a small hole for better results.</p>
--	---

## 2. EXTERNAL ACCESSORIES

### 2.1 CONNECTING EXTERNAL ACCESSORIES



#### PLEASE NOTE

- The unit must be disconnected from the power supply to connect accessories.
- All external control components must be connected according to the wiring diagram.

#### 2.1-1 DS door contact



#### TECHNICAL INFORMATION

- suitable for all SM regulation
- Isolated switching contact with maximum voltage 230V, 6A
- IP67, can be connected as a break or switching contact



#### CAUTION!

Not included with the product.

#### 2.1-2 DK-1 / DK-B3 door contact



#### TECHNICAL INFORMATION

- Isolated switching contact with maximum voltage 12V.
- Cable - Two-core cable with a cross section of 0,5 mm<sup>2</sup>. - Maximum length: 50 m



#### ATTENTION!

Not included with the product.

#### 2.1-3 Thermostatic valve – TV1/1



#### TECHNICAL INFORMATION

- Thermostatic valve to regulate the water exchanger
- Suitable for all types of curtain with water exchanger
- Works independent to the electronic controls



#### CAUTION!

Not included with the product.

#### 2.1-4 Zone valve ZV3 / RT-3-xx



#### TECHNICAL INFORMATION

- Zone valve to regulate the water exchanger
- Cable - Three-core cable with a cross-section of 1.5 mm<sup>2</sup>, 230 V/ 50 Hz.

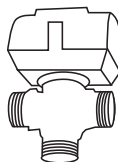

#### CAUTION!

Not included with the product.



## 2. EXTERNAL ACCESSORIES

### 2.1-5 Room thermostat - TER-P

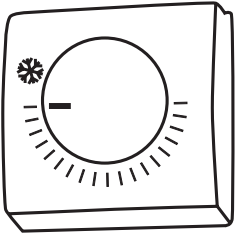

#### **TECHNICAL INFORMATION**

- Room thermostat to regulate heating
- Cable - Two-core cable with a cross-section of 0.5 mm<sup>2</sup>, 230 V/ 50 Hz.

#### **ATTENTION!**

**Not included with the product.**

## 3. COMMISSIONING



#### **PLEASE NOTE**

Before starting up the unit, check the following:

- Did you leave inside tools or objects that could damage the unit?
- Is the supply of energy and heating water (if applicable) adequate?
- Is the unit well closed?
- Is the control module properly connected?
- Does the unit have adequate protection according to the applicable standards?

## 4. MAINTENANCE

### 4.1 CLEANING



#### **ATTENTION!**

- Do not use compressed air, chemicals, solvents or water to clean the unit.
- Use a soft brush or a vacuum cleaner to clean the suction cover and the inside of the unit.
- See the installation manual of the ESSENSE NEO curtain

## 5. SERVICE

### 5.1 IF YOU ARE UNABLE TO REPAIR THE UNIT

If you were unable to solve a problem, contact the supplier or the representative of 2V. Warranty and post-warranty service are provided by the supplier or an authorised service included in the list available at the supplier's.

Give the following information to the supplier or service:

- **type designation of the air curtain**
- **accessories in use**
- **place of installation**
- **serial number**
- **conditions of the installation (incl. electrical)**
- **period of operation**
- **detailed description of the malfunction**

### 5.2 – DECOMMISSIONING THE PRODUCT – LIQUIDATION

Before scrapping the product, make it unusable. Old products still have raw materials that can be reused. Take them to a collection centre for secondary raw materials. It is preferable to have the product liquidated by a specialist so that the recyclable materials may be reused. Take the unusable parts to an appropriate waste disposal site.



The liquidation of materials must observe the applicable waste management regulations.

# 6. WIRING DIAGRAM

## RGJ3-VCES2-CO-S-MA

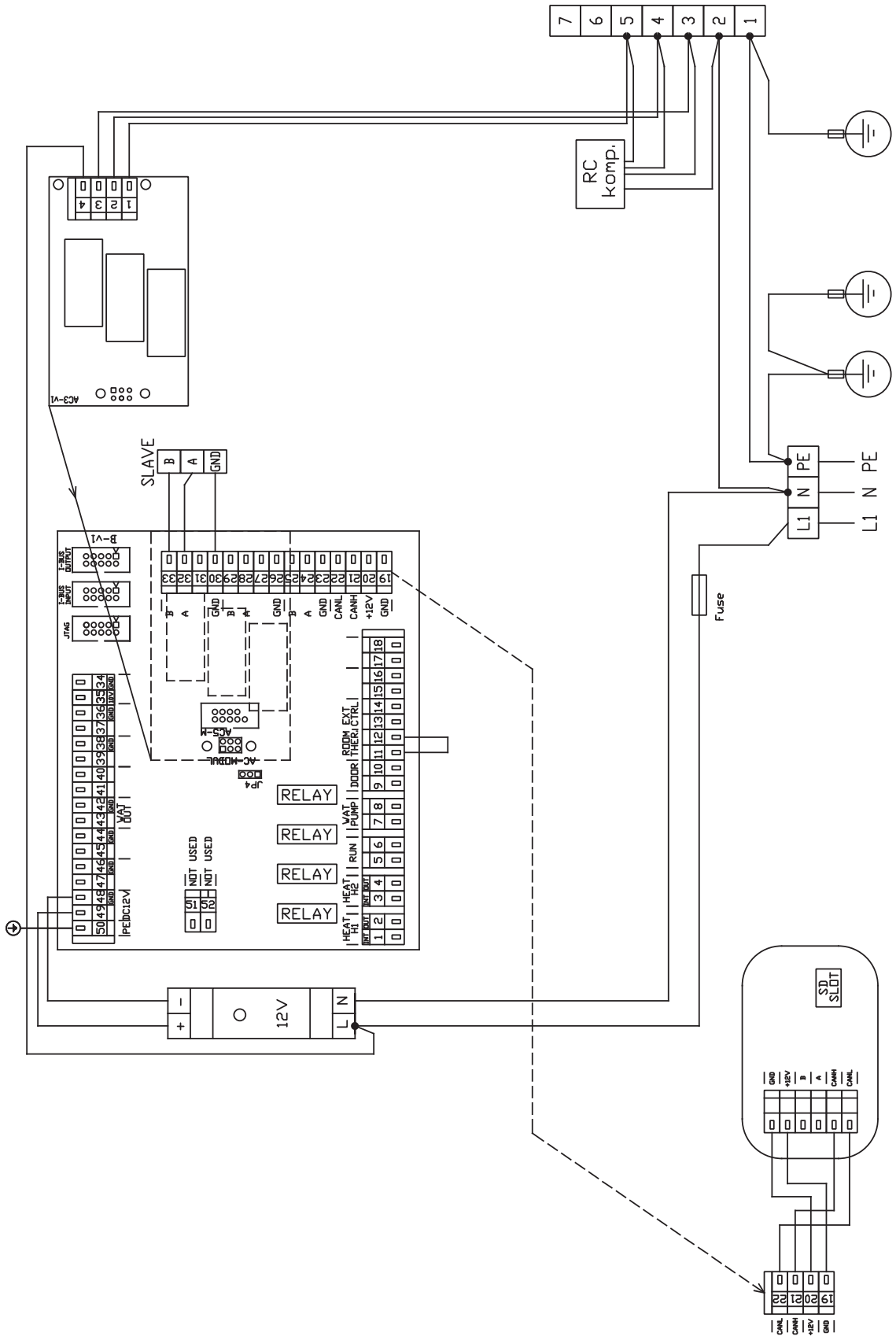

# 6. WIRING DIAGRAM

## RGJ3-VCES2-CO-E-MA

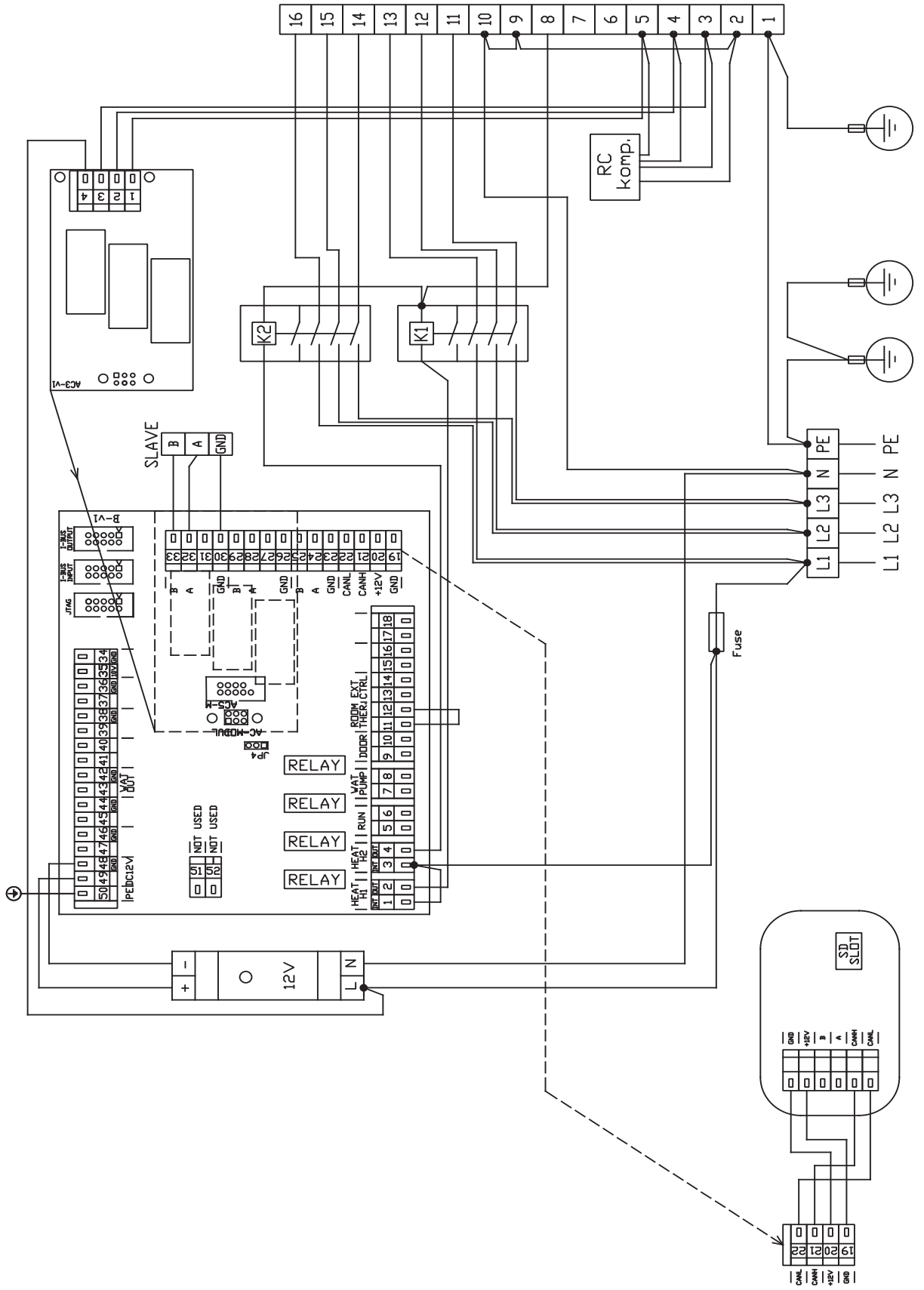

# 6. WIRING DIAGRAM

## RGJ3-VCES2-CO-V-MA

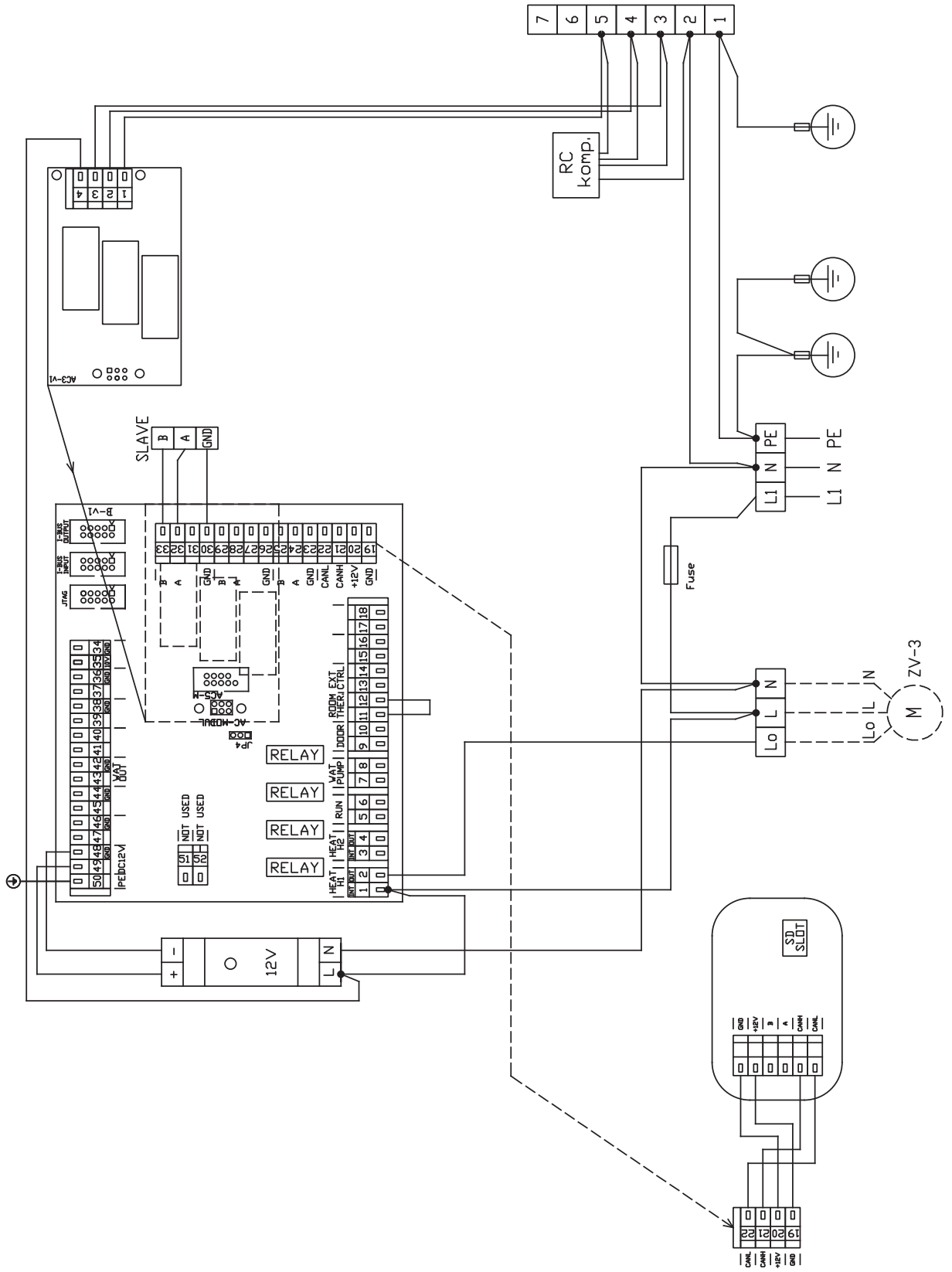

# 6. WIRING DIAGRAM

## RGJ3-VCES2-CO-S-SL

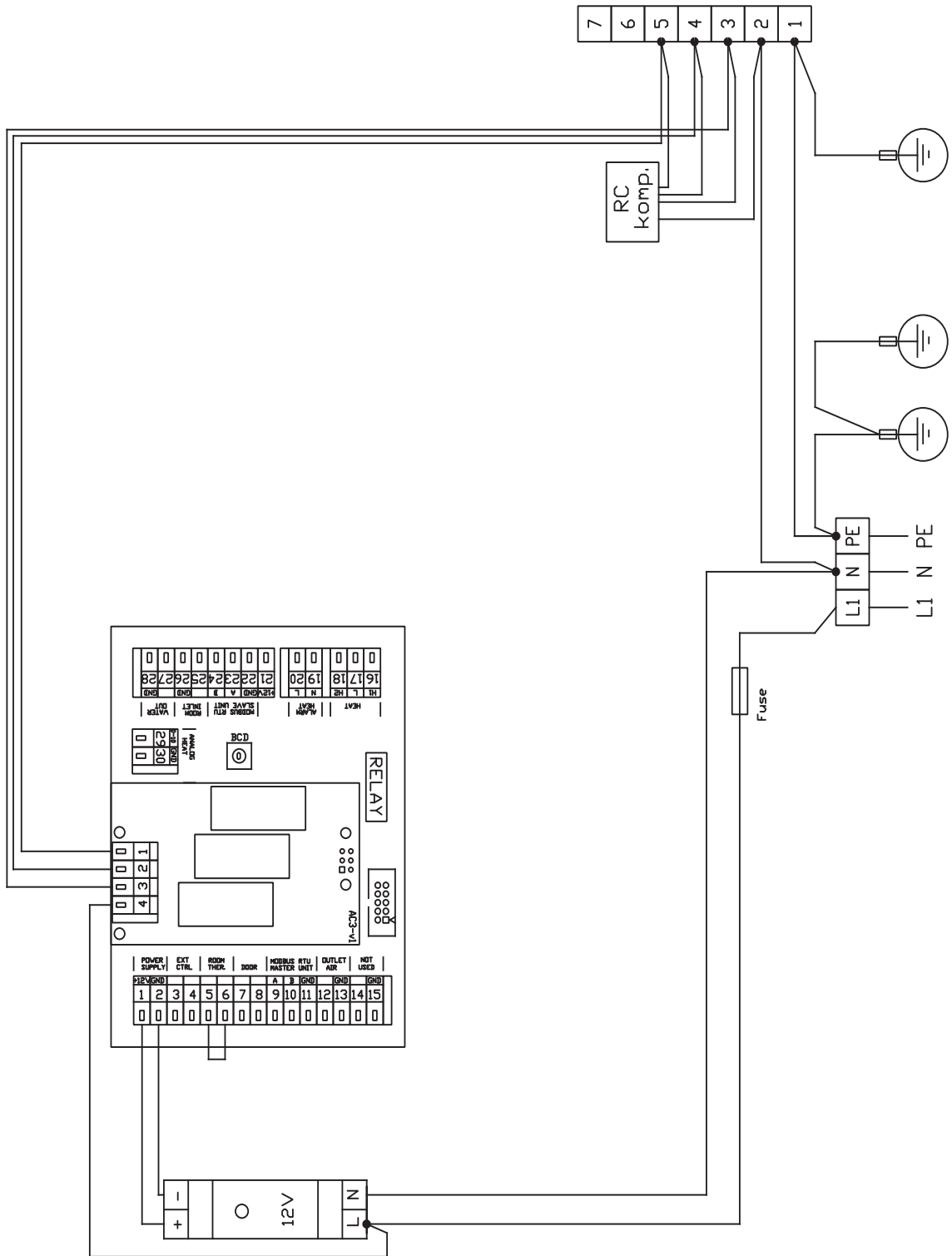

## 6. WIRING DIAGRAM

# RGJ3-VCES2-CO-E-SL

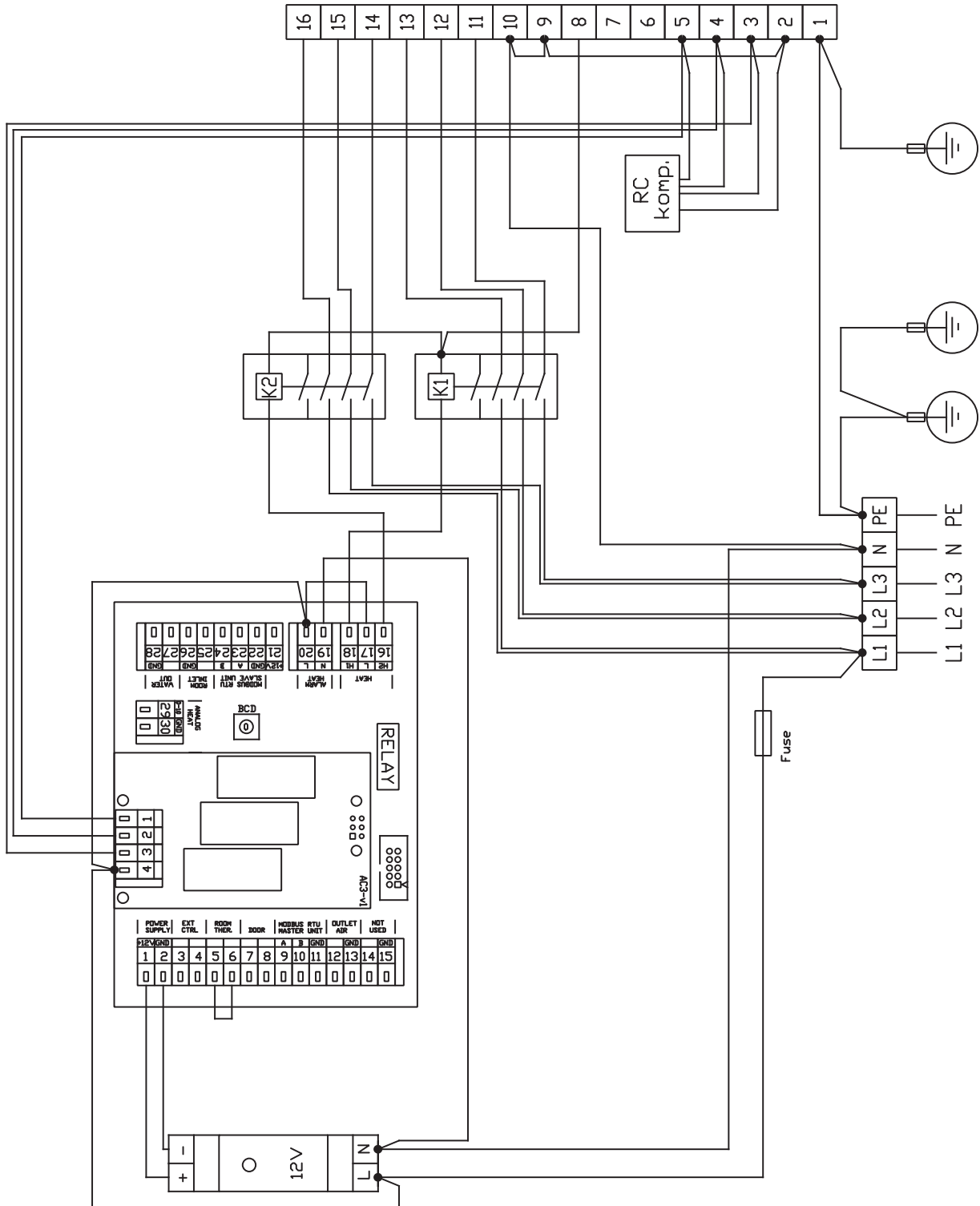

# 6. WIRING DIAGRAM

## RGJ3-VCES2-CO-V-SL

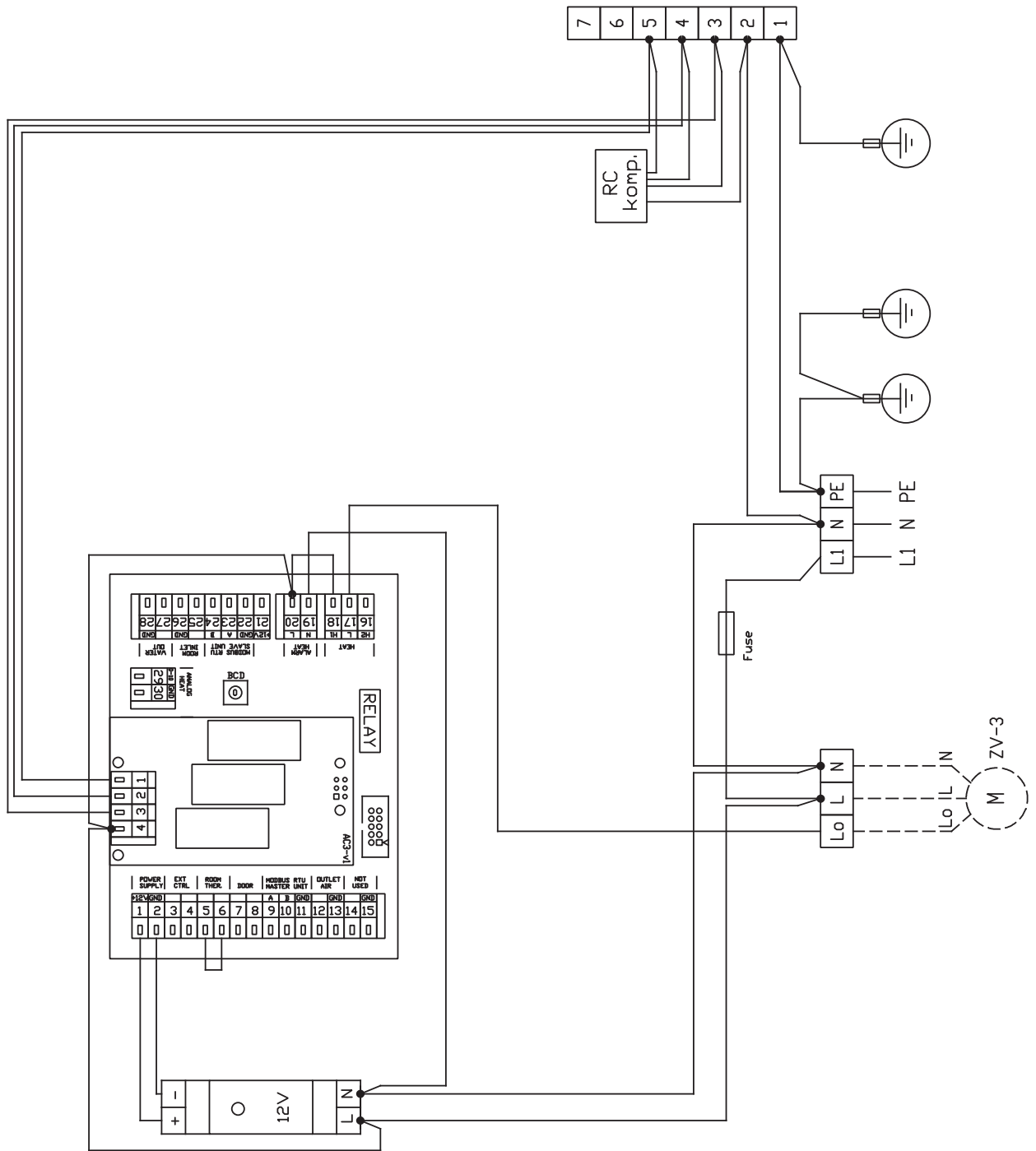



## 7. CONCLUSION

### 7.1. CONCLUSION

In case of any doubt or query, do not hesitate to contact our sales or technical support departments.



2VV, s.r.o.  
Fáblovka 568  
533 52 Pardubice  
Czech Republic



+420 466 741 811



[www.2vv.cz](http://www.2vv.cz)



support@2vv.cz

